

CONTROL PANEL
لوحة التحكم

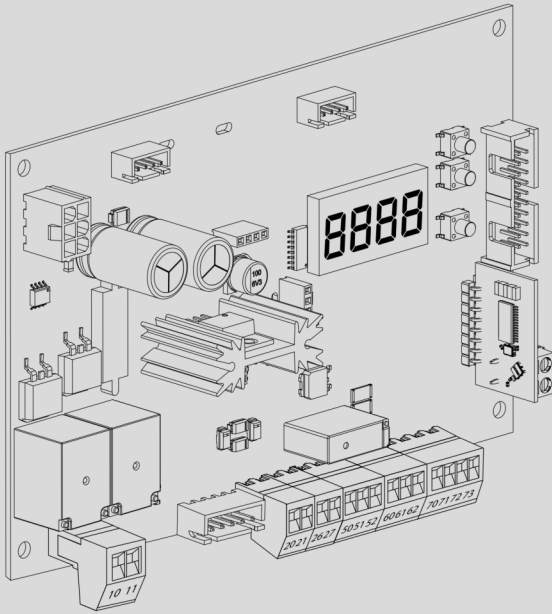

INSTALLATION MANUAL
دليل التركيب

NE NOISREV DETALS NART
RA النسخة المترجمة

BFT





AZIENDA CON
SISTEMA DI GESTIONE
CERTIFICATO DA DNV GL
= ISO 9001 =
= ISO 14001 =



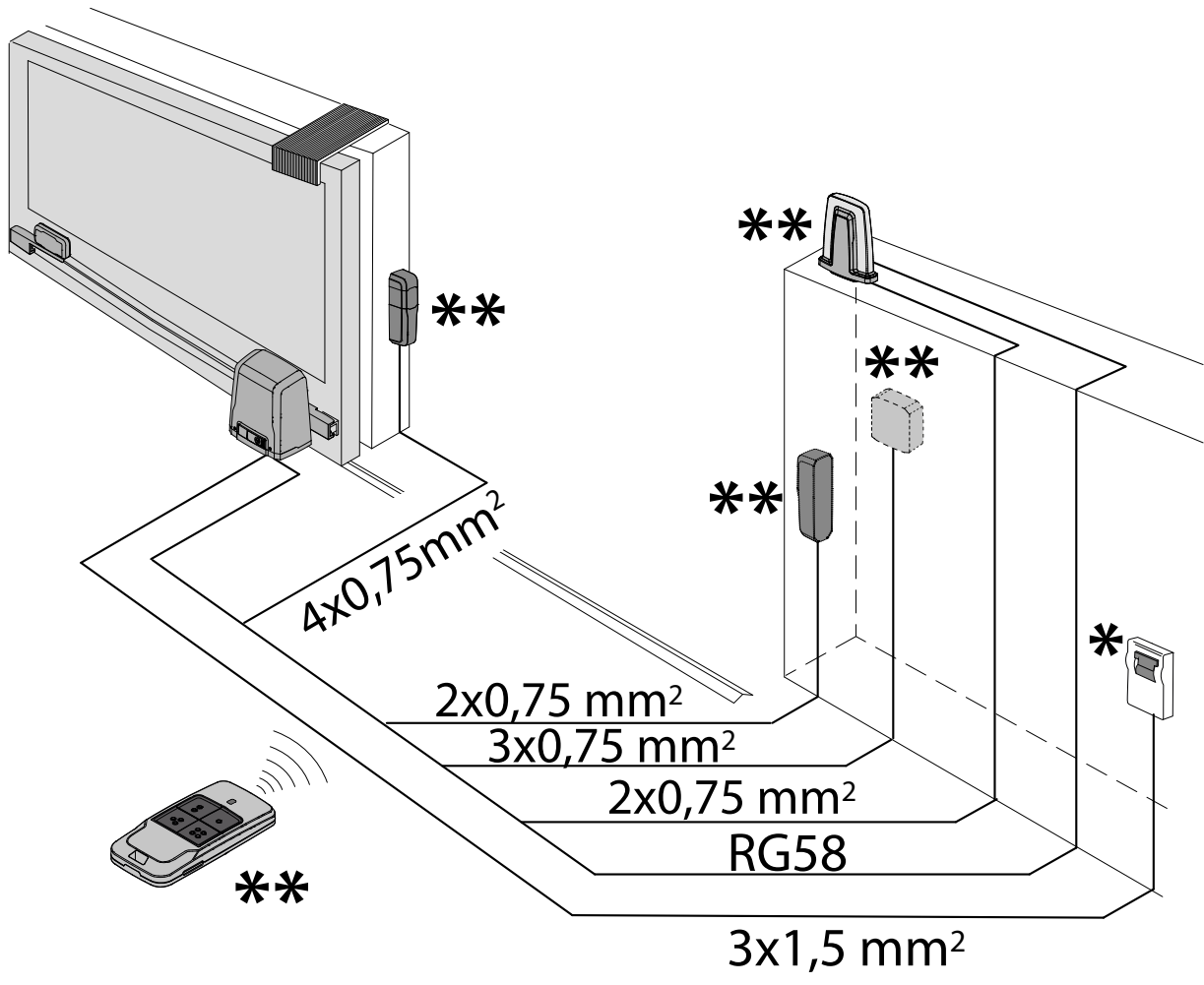

TUBE ARRANGEMENT
إدارة الأنابيب

Example



* 
BUY

** 
BUY → 

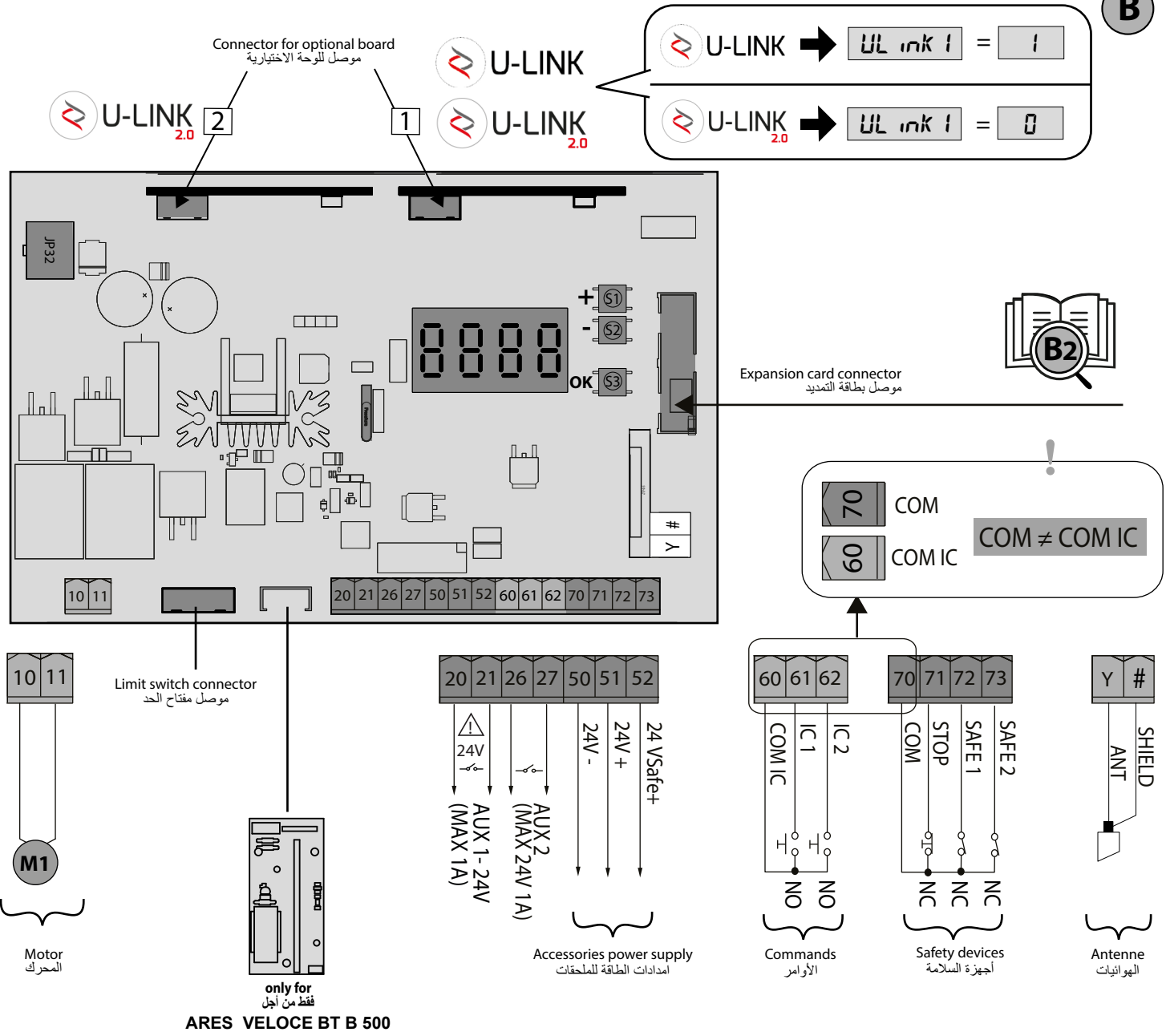

ARES VELOCE BT B 500

	10	11	
	Ares	Deimos	Ares/Deimos
EN	Black	Blue	Red
AR	أسود	أزرق	أحمر

EXAMPLE

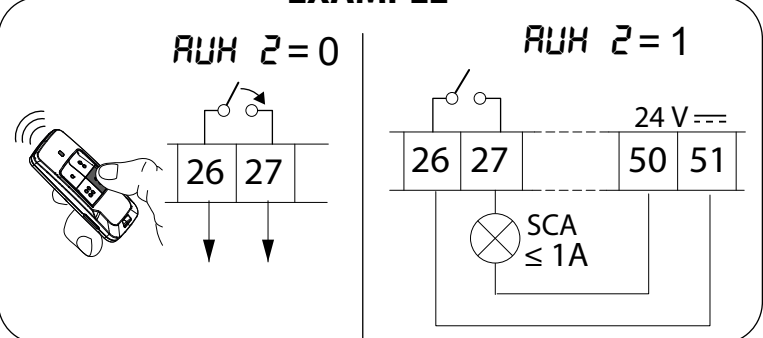

DIAGNOSTICS



↓

 **PAGE 8-23-24**
38-37-8 الصفحة

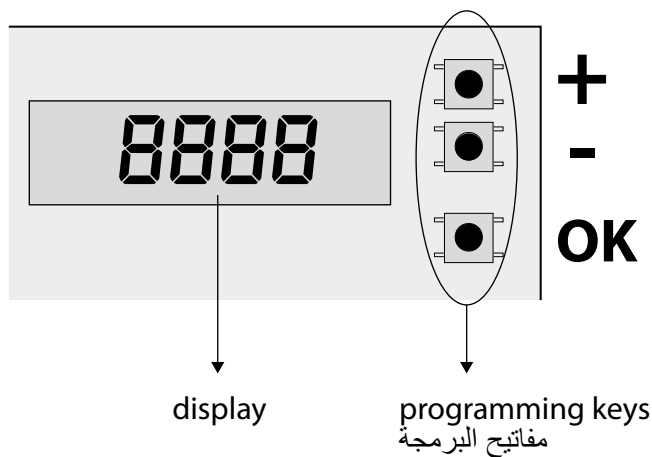



















display

programming keys
مفاتيح البرمجة

+

-

OK

	+	 < 2s	OPEN / STOP فتح / إيقاف
		 > 5s	Add 1st radio channel إضافة قناة الراديو الأولى
		 x1	↑ scroll through the menu التمرير عبر القائمة
	-	 < 2s	CLOSE / STOP إغلاق / إيقاف
		 > 5s	Add 2nd radio channel إضافة قناة الراديو الثانية
		 x1	↓ scroll through the menu التمرير عبر القائمة
	OK	 > 5s	start autoselect بدء الضبط التلقائي
		 x1 ENTER	start guided procedure / confirm selection بدء الإجراء الموجه / تأكيد الاختيار
		 x2 ENTER	enter advanced menu الدخول إلى القائمة المتقدمة
	+	 > 5s	transmitters cancellation إلغاء جهاز الإرسال
		 x7	ESC
	-	 x7	exit menu خروج من القائمة
			

EXPANSION BOARD - لوحة التوسعة

B1

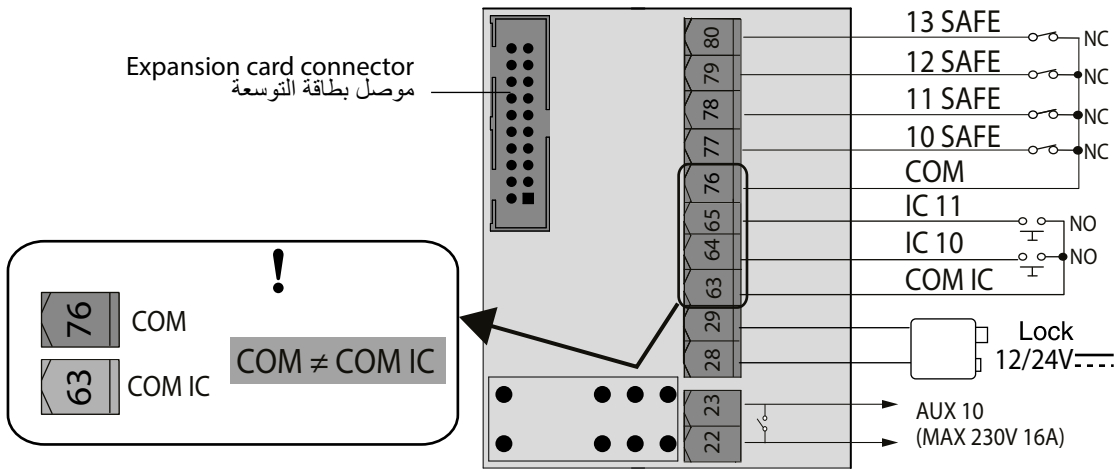

ELECTRICAL LOCK connection example

B2

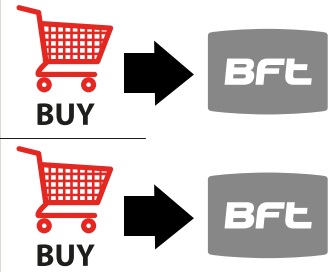
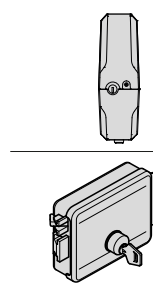
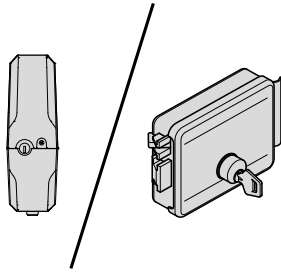

1 EBP BT
24V

1 ECB
12V

1 ECB
24V

🇬🇧 Lock = 4

🇬🇧 Lock = 0

🇬🇧 Lock = 2

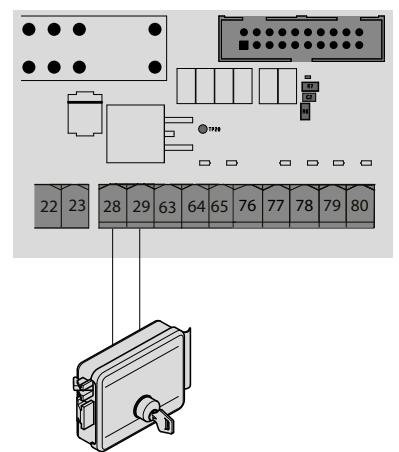
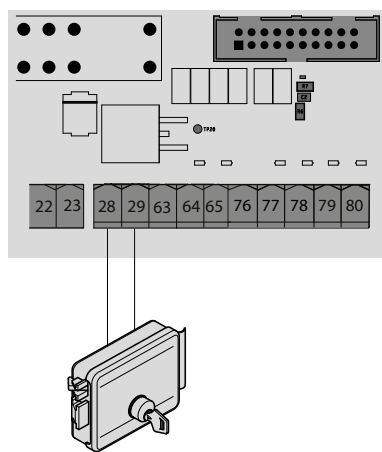
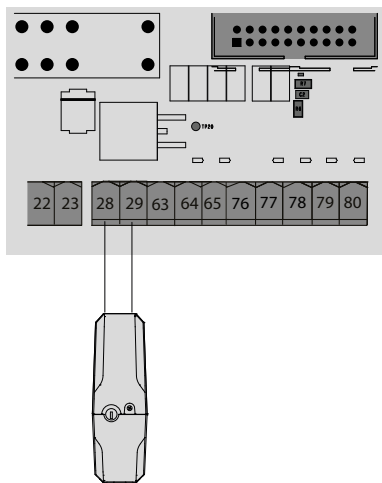

24 V

SAFE 1 / SAFE 2 Connection Example

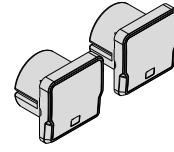
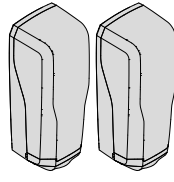
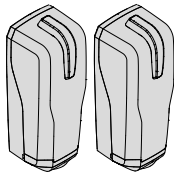
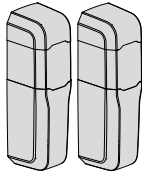

Photoceils not checked (Check every 6 months)
لم يتم فحص الخلايا الضوئية (الفحص كل 6 أشهر)

C

Photoceill checked
تم فحص الخلايا الضوئية

D

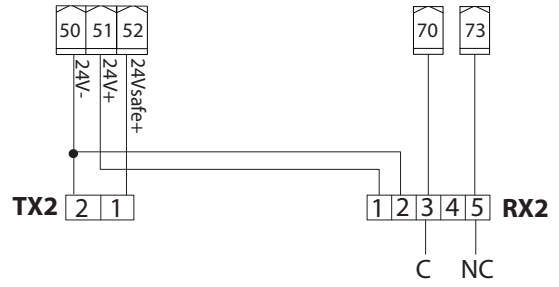
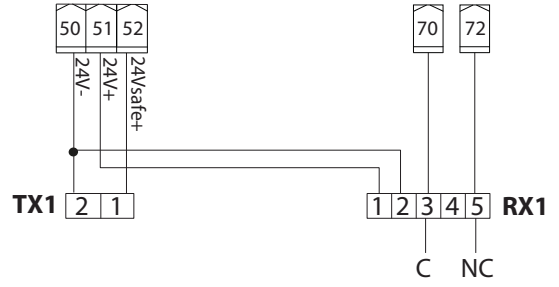
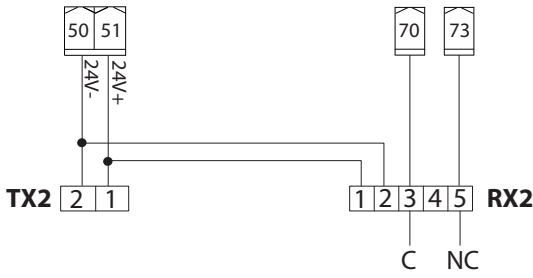
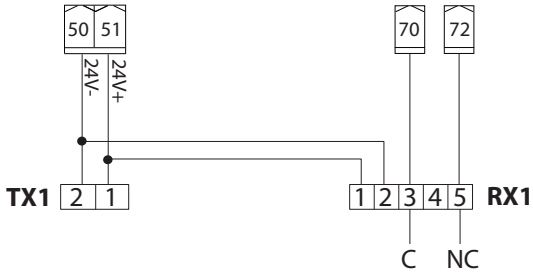

ENGLISH

IT IS NECESSARY TO FOLLOW THIS SEQUENCE OF ADJUSTMENTS:

- 1 - Autose
- 2 - Programming remote controls
- 3 - Setting of parameters/logic, where necessary

اللغة العربية

من الضروري اتباع هذا التسلسل من التعديلات:

- 1 - ضبط تلقائي
- 2 - برمجة وحدات التحكم عن بُعد
- 3 - ضبط المؤشرات/المنطق، حسب الضرورة

INSTALLATION ALTERNATIVES

بدائل التركيب

E

1

DEIMOS ULTRA BT B 400
DEIMOS ULTRA BT B 600
ARES ULTRA BT B 1000
ARES ULTRA BT B 1500

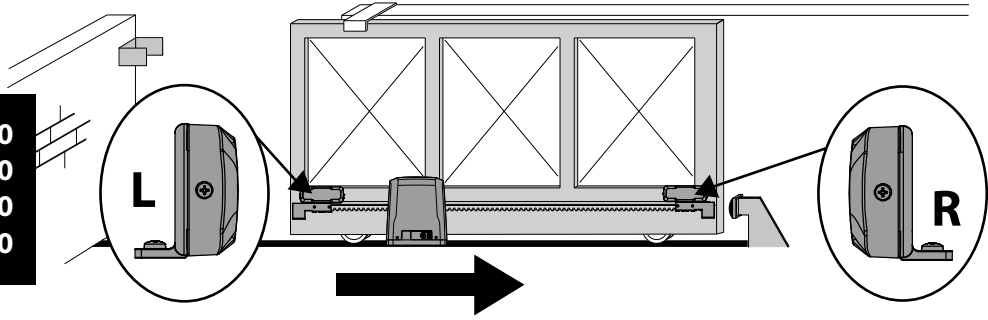

ARES VELOCE BT B 500
ARES VELOCE BT B 1000

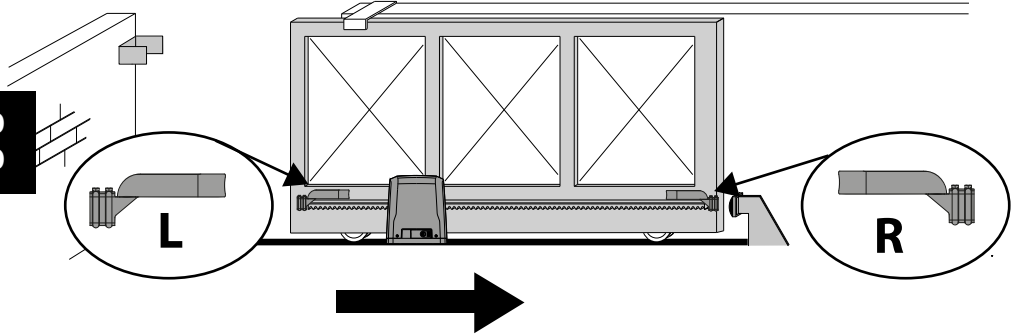

opening direction: right
اتجاه الفتح: يمين

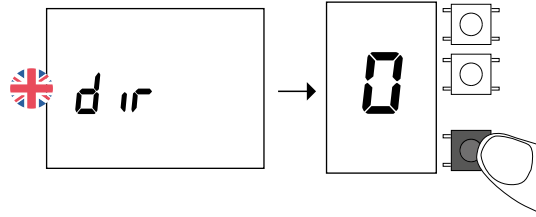

DEIMOS ULTRA BT B 400
DEIMOS ULTRA BT B 600
ARES ULTRA BT B 1000
ARES ULTRA BT B 1500

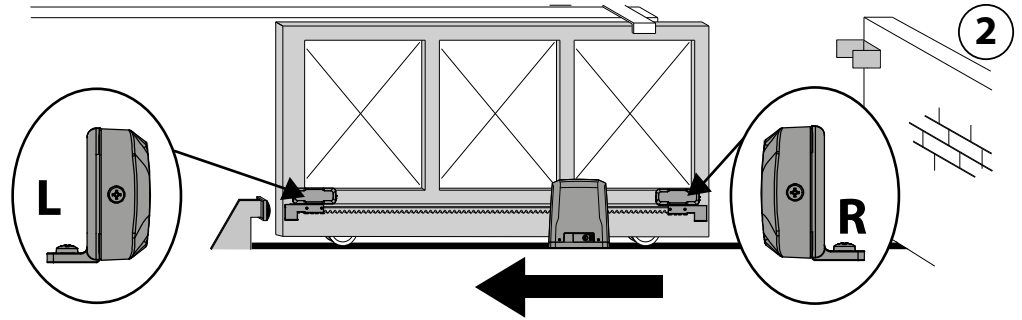

2

ARES VELOCE BT B 500
ARES VELOCE BT B 1000

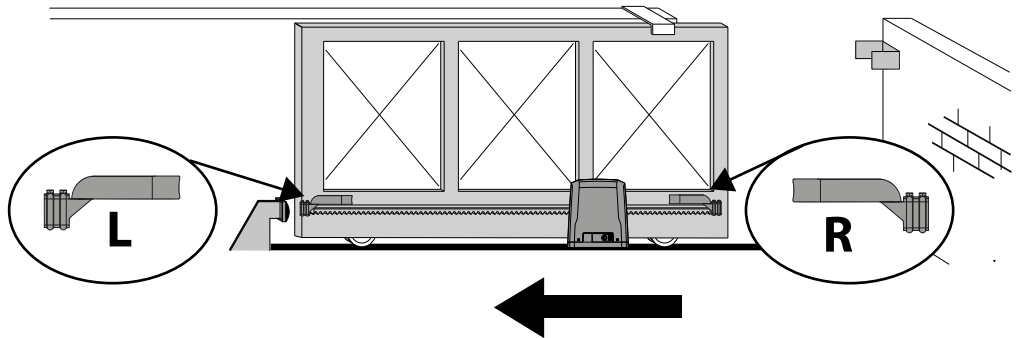

opening direction: left
اتجاه الفتح: يسار

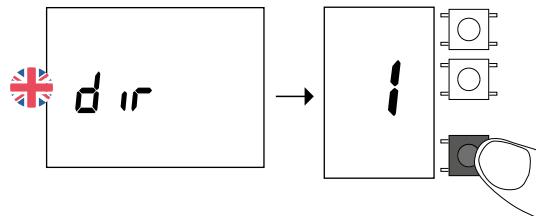

DIAGNOSTICS

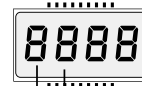
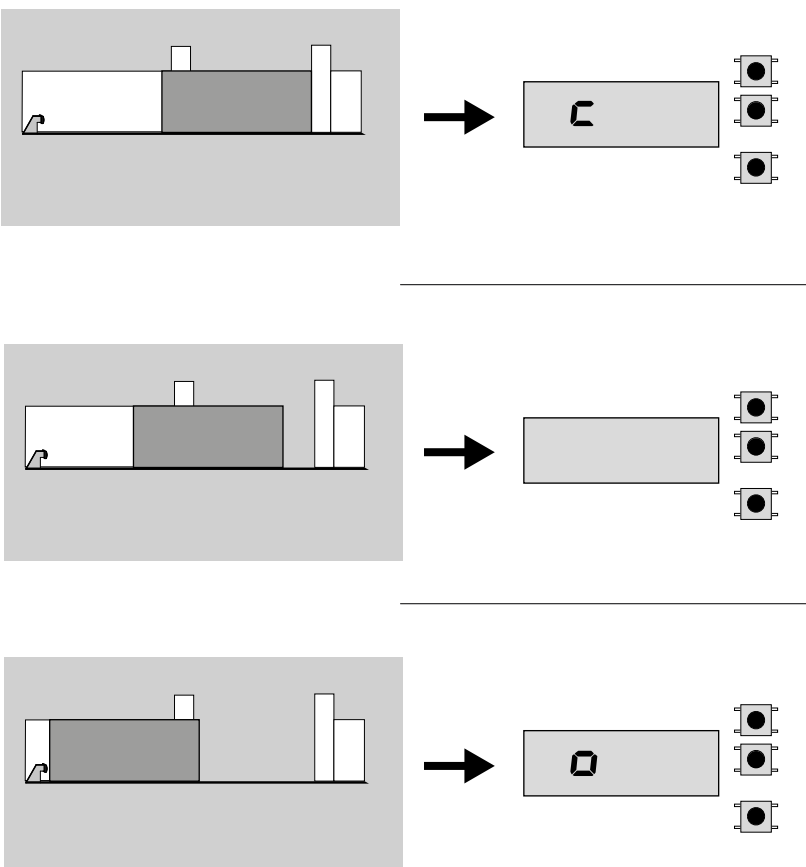
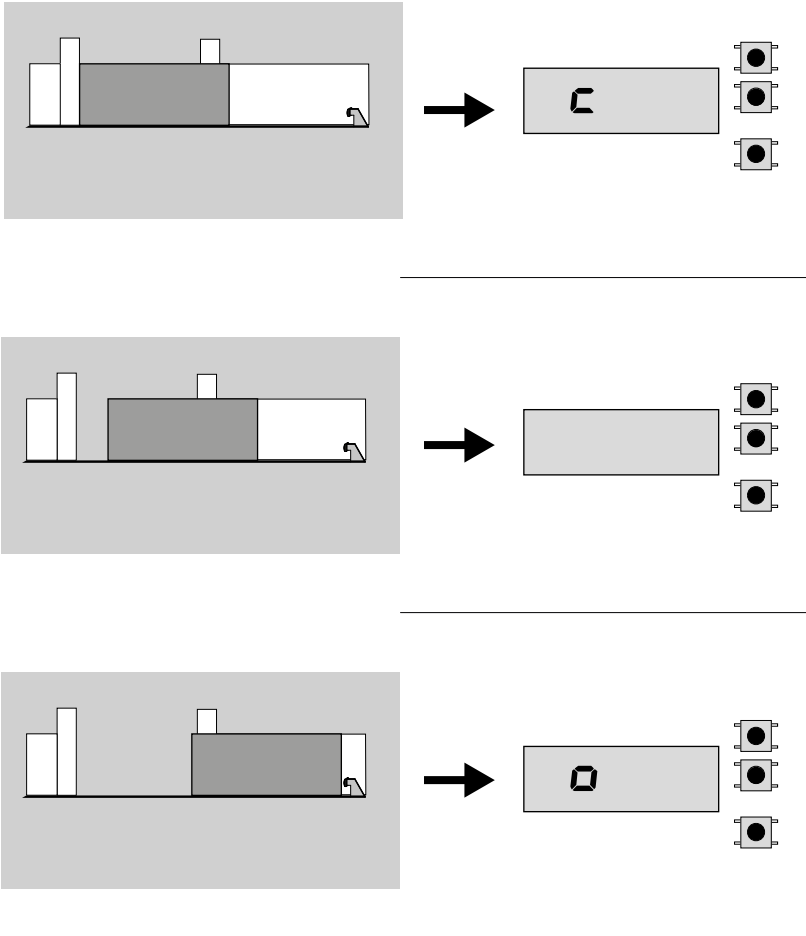

c = Activation of SWC closure limit-switch input
 =c = تنشيط إدخال المفتاح الحدي لإغلاق SWC

o = Activation of SWO opening limit-switch input
 =o = تنشيط إدخال المفتاح الحدي لفتح SWC

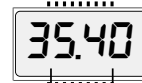

Force set by autose
 قوة يتم ضبطها بواسطة الضبط التلقائي

Instantaneous force motor
 قوة المحرك الفورية

ONLY FOR
 فقط من أجل

ARES VELOCE BT B 500
ARES VELOCE BT B 1000

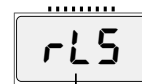

activation of mechanical release of the motor.
 تفعيل التحرير الميكانيكي للمحرك.

SAFE1 - SAFE2

TEST ON

Photozell checked
تم فحص الخلايا الضوئية

TEST OFF

Photocells not checked (Check every 6 months)
لم يتم فحص الخلايا الضوئية (الفحص كل 6 أشهر)

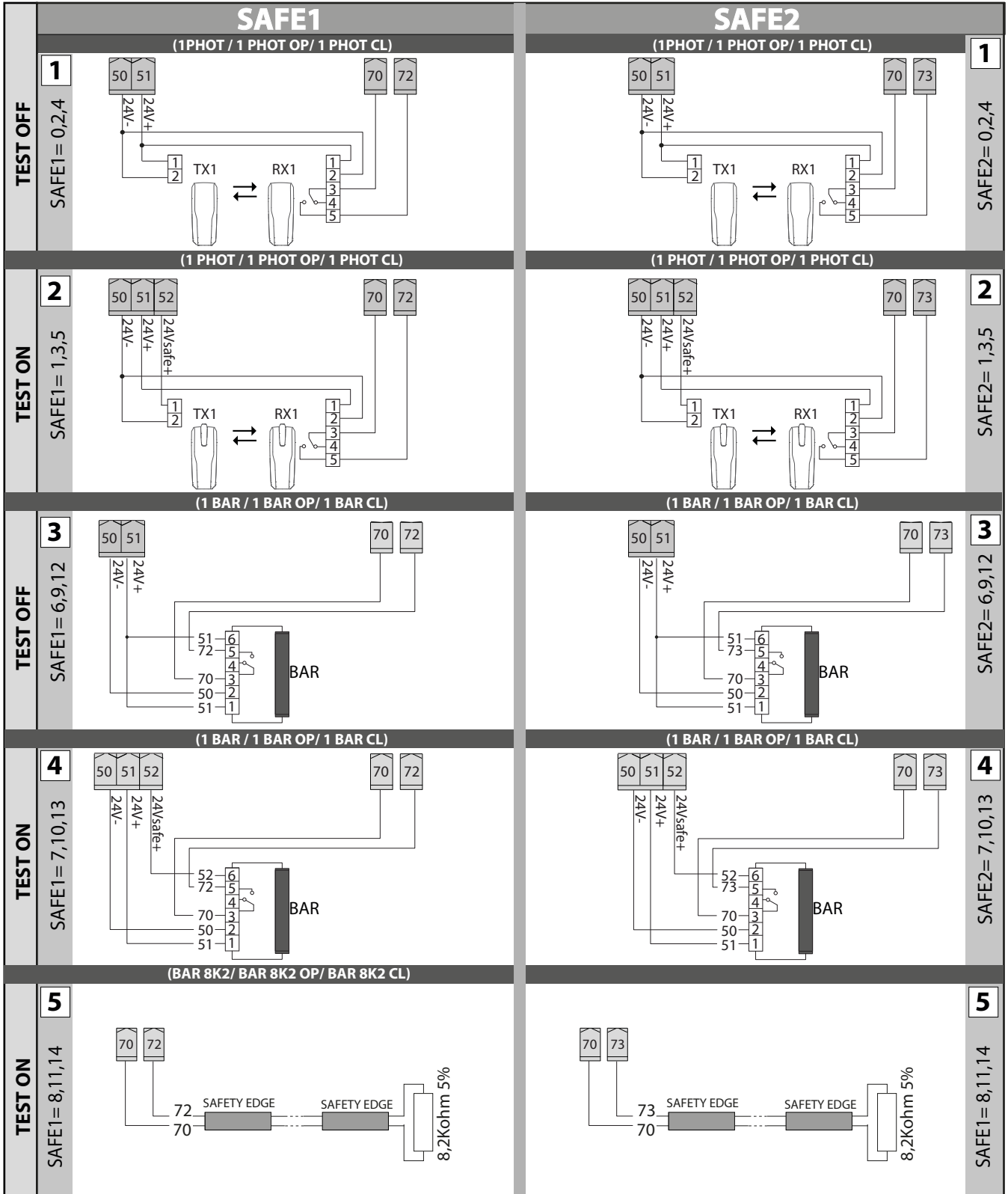

SAFE10 - SAFE11

ONLY WITH AN EXPANSION CARD

فقط مع بطاقة التوسعة

F

D814459 OAR16_08

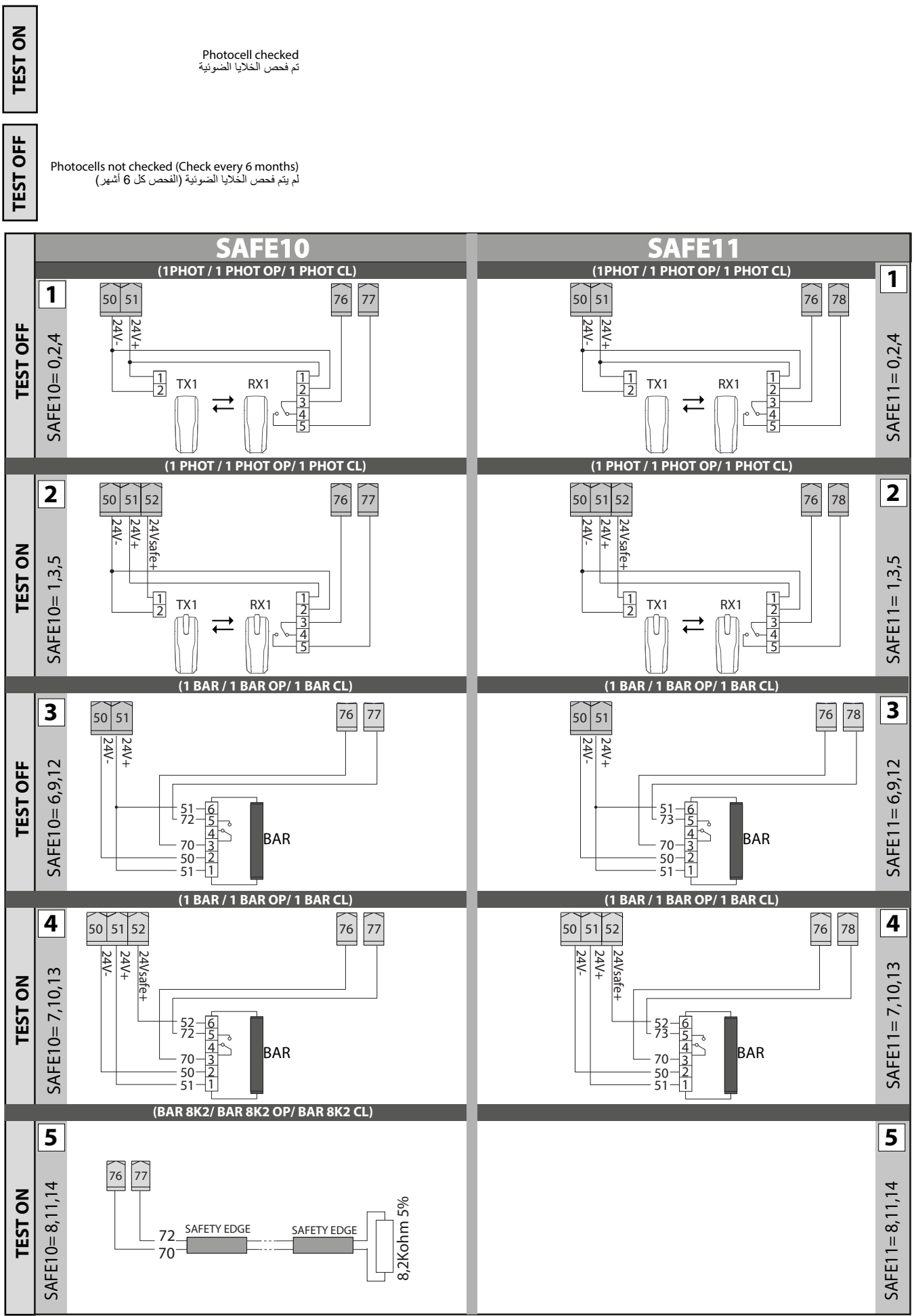

SAFE12 - SAFE13

ONLY WITH AN EXPANSION CARD
فقط مع بطاقة التوسعة

TEST ON

Photocell checked
تم فحص الخلايا الضوئية

TEST OFF

Photocells not checked (Check every 6 months)
لم يتم فحص الخلايا الضوئية (الفحص كل 6 أشهر)

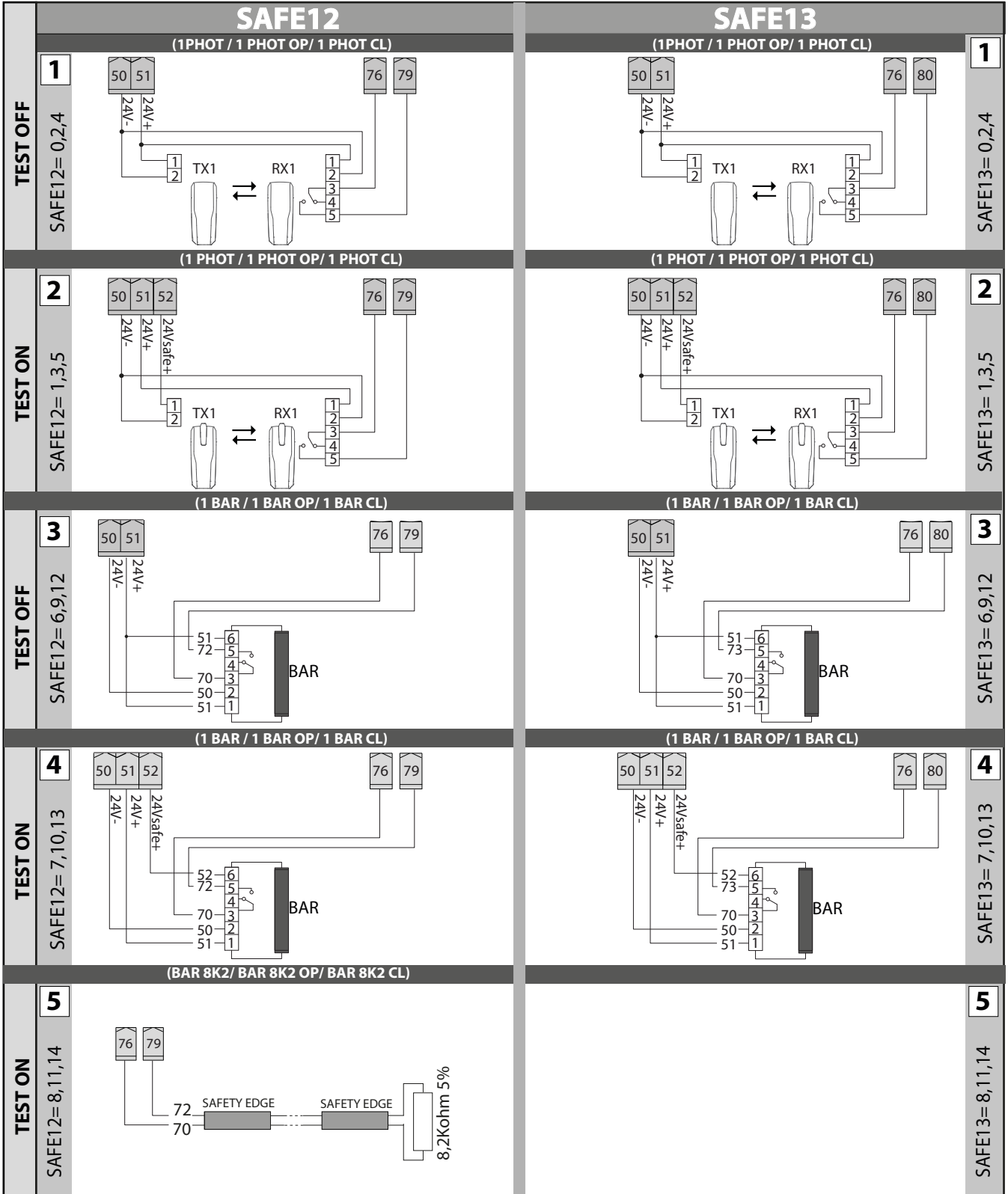



Read the legend CAREFULLY. It contains important information for successful programming of the motor.

اقرأ العنوان الرئيسي بعناية. يحتوي على معلومات مهمة لبرمجة المحرك بنجاح.

KEY

العنوان الرئيسي



(EN) Press the OK button 2 times in quick succession
(العربية) اضغط على زر موافق 2 مرات في تعاقب سريع



(EN) press until the desired parameter appears
(العربية) اضغط حتى تظهر المعلمة المطلوبة

PrG

(EN) Programming
(العربية) برمجة

EN OPENING TO THE RIGHT
 عربي الفتح إلى اليمين

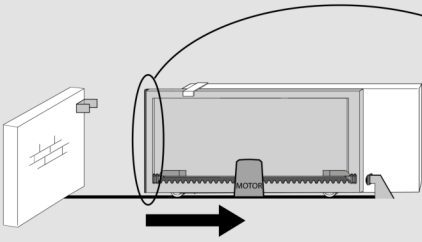

EN12453
CE CONFORMITY

**

DEIMOS ULTRA BT B 400/600
 ARES ULTRA BT B 1000/1500

**

ARES VELOCE BT B 500/1000

Mod. CSP
 Cod. N190039
 Cod. N190040
 Cod. N190041

**

Active Safety Edge
 EN12978

8888

+ / ↑

8888

- / ↓

OK / ENTER

8888

ESC

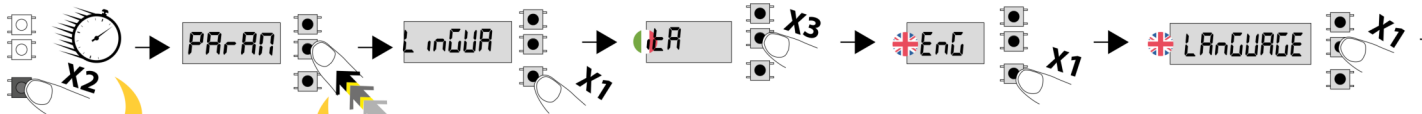

Press the OK button 2 times in quick succession
 اضغط على زر موافق 2 مرات في تعاقب سريع

press until the desired parameter appears
 اضغط حتى تظهر المعلمة المطلوبة

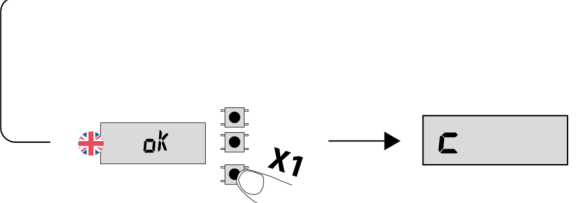
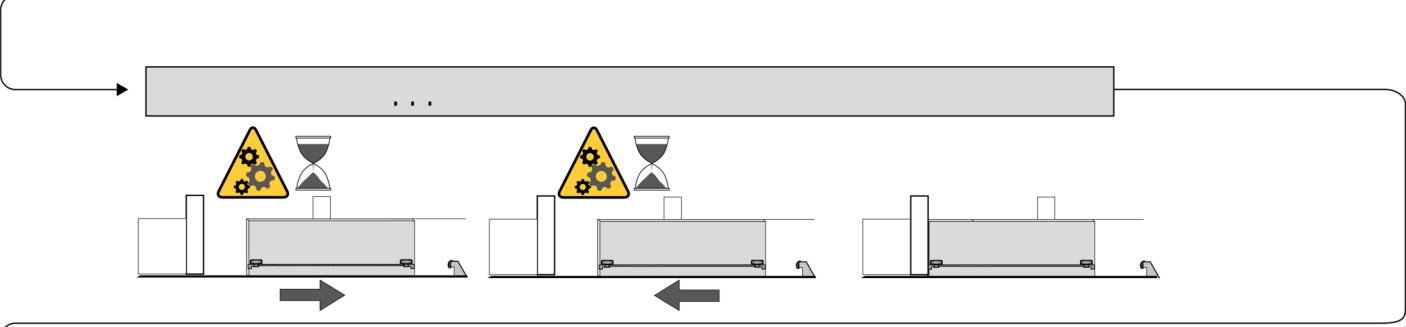
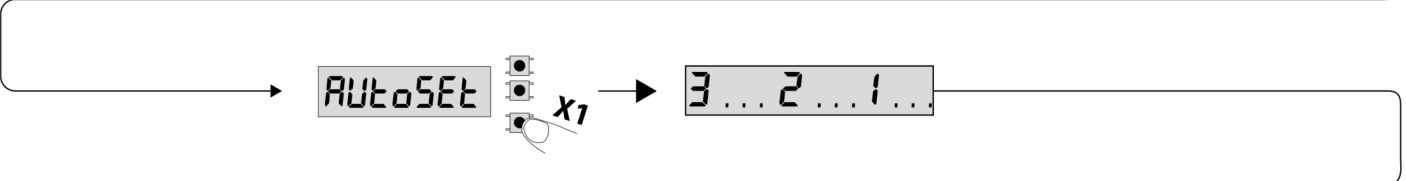

EN OPENING TO THE LEFT
عربي الفتح إلى اليسار

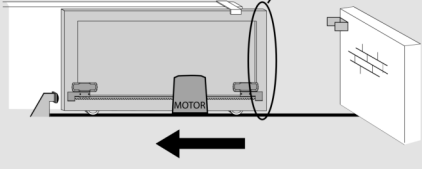

 EN12453 CE CONFORMITY	
** DEIMOS ULTRA BT B 400/600 ARES ULTRA BT B 1000/1500	** ARES VELOCE BT B 500/1000
 Mod. CSP Cod. N190039 Cod. N190040 Cod. N190041	** Active Safety Edge EN12978

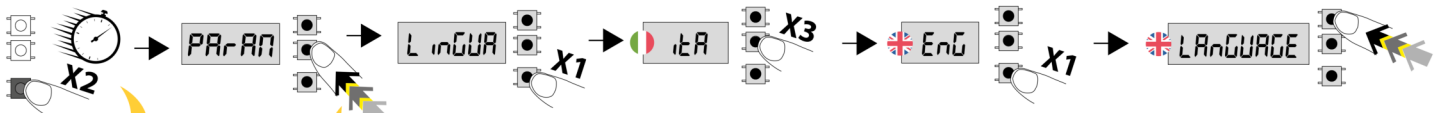
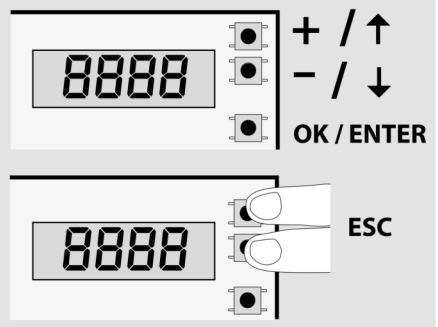

Press the OK button 2 times in quick succession
اضغط على زر موافق 2 مرات في تعاقب سريع

press until the desired parameter appears
اضغط حتى تظهر المعلمة المطلوبة

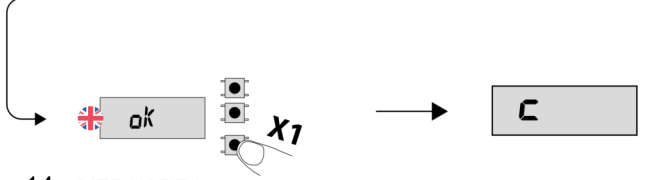
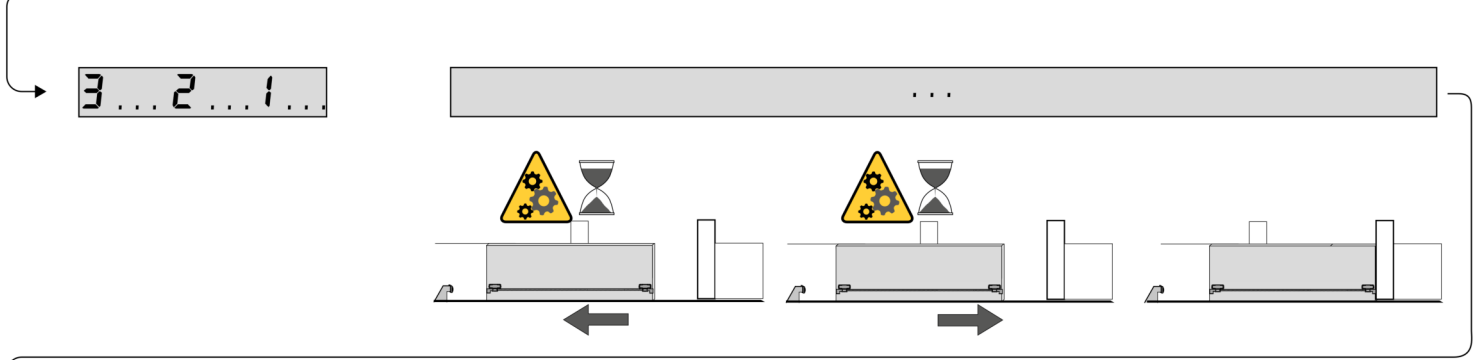
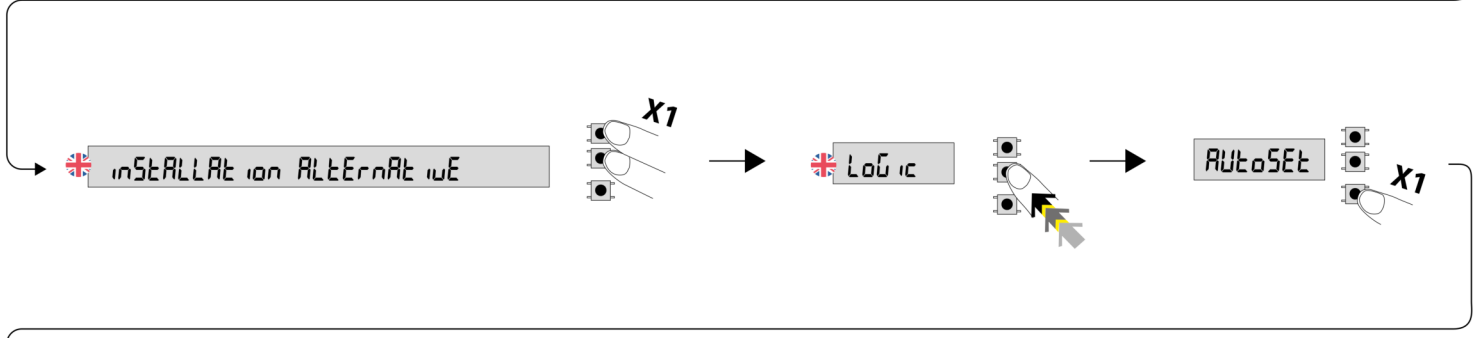
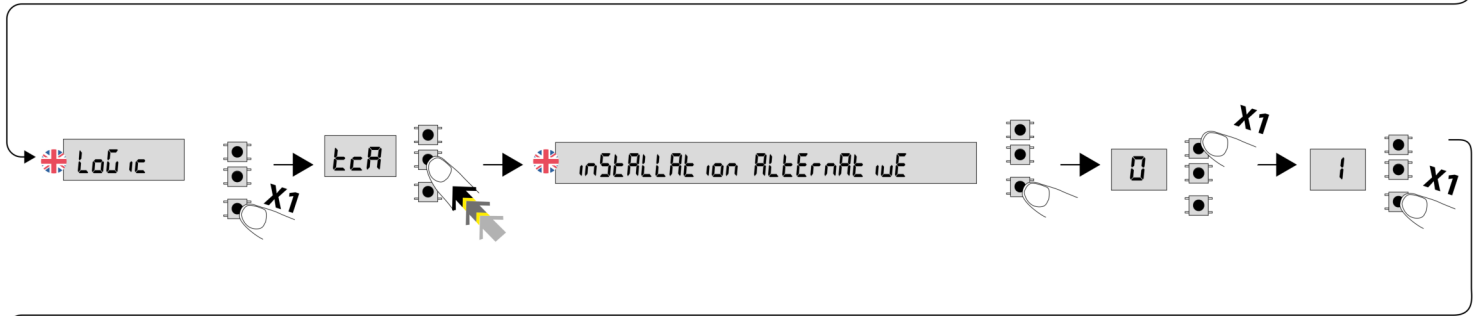

MEMORISATION OF TRANSMITTERS تخزين أجهزة الإرسال

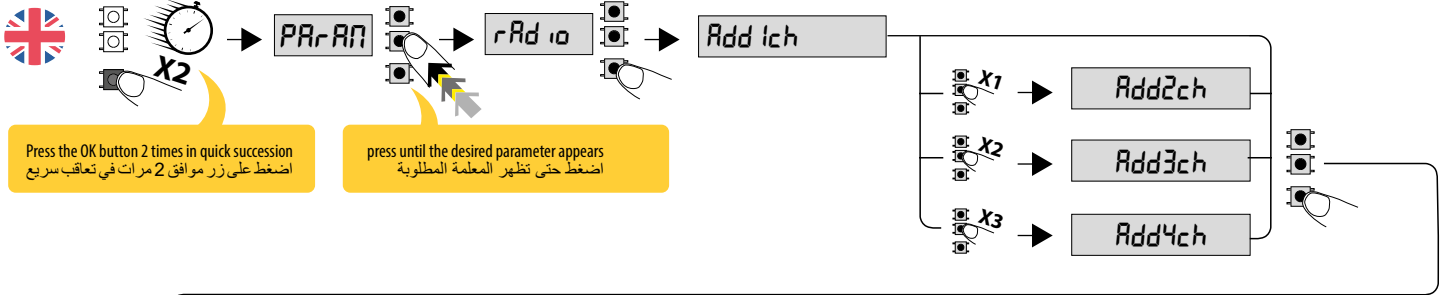

Press the OK button 2 times in quick succession
اضغط على زر موافق 2 مرات في تعاقب سريع

press until the desired parameter appears
اضغط حتى تظهر المعلمة المطلوبة

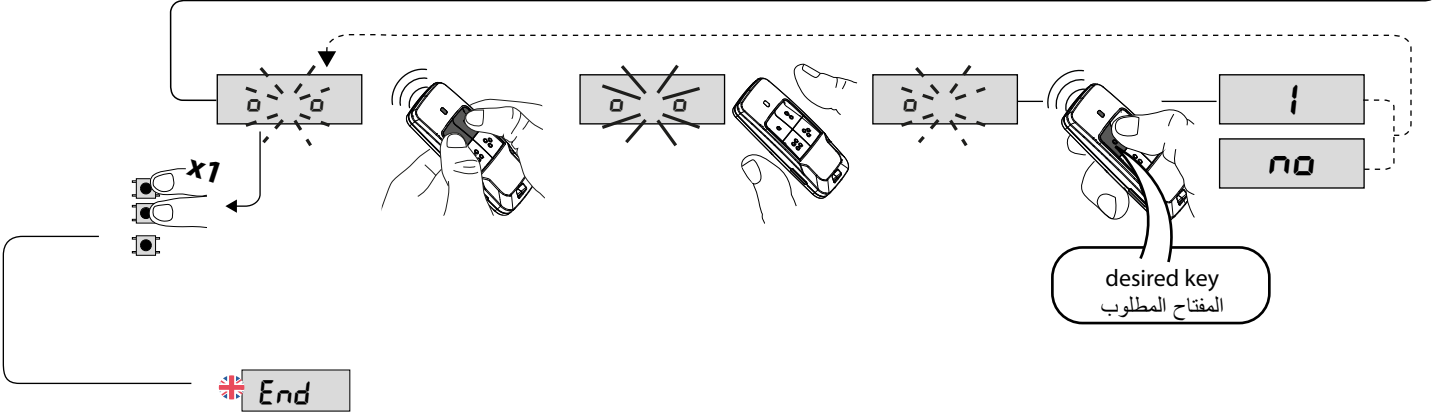

TRANSMITTERS CANCELLATION

إلغاء الإرسال

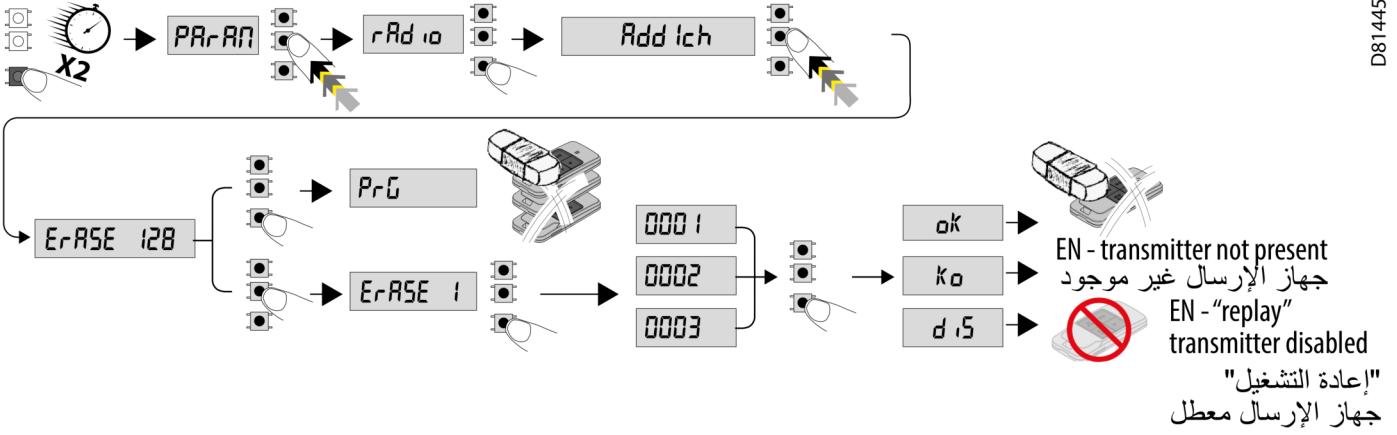

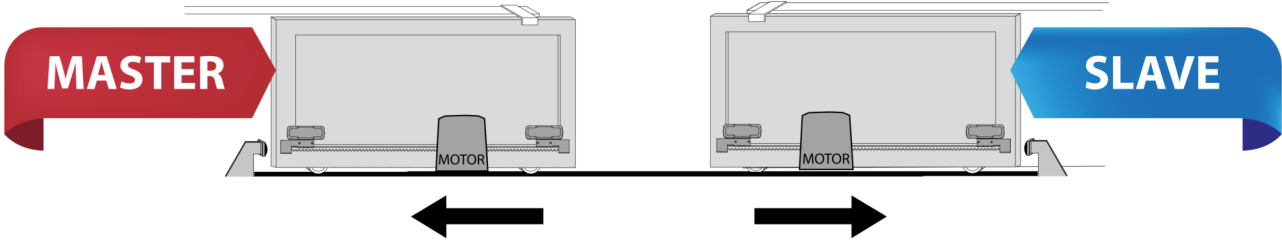

Address = 0
Serial Node = 3
Link = 1

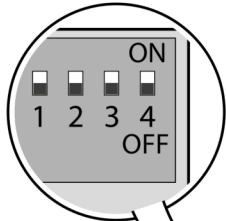

MAX 250m

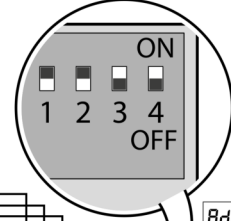

Address = 0
Serial Node = 2
Link = 1

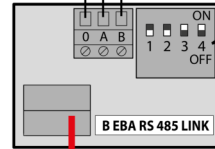
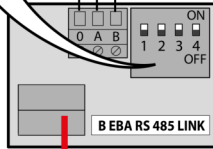

MASTER

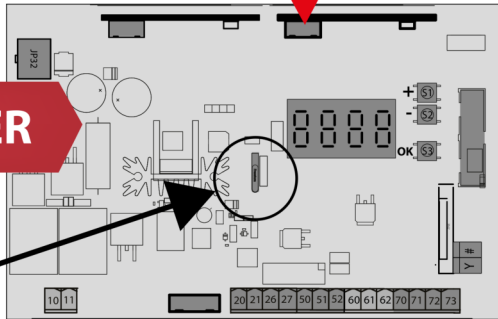

SLAVE

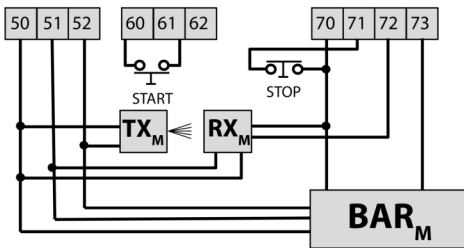
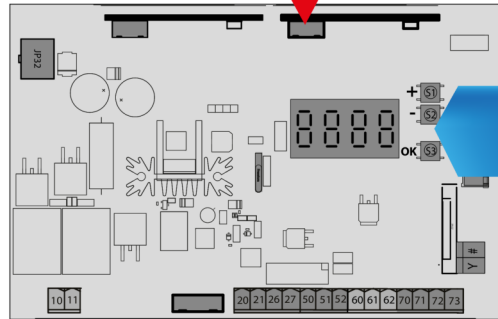

SAFE 1 = 1
SAFE 2 = 7 (≥6)

SAFE 2 SLAVE = SAFE 2 MASTER

THE AUTO-SET MUST BE PERFORMED SEPARATELY ON THE 2 LEAVES BEFORE SETTING THE FUNCTION OF THE OPPOSITE LEAVES.

يجب إجراء الضبط التلقائي بشكل منفصل على الورقتين قبل ضبط وظيفة الورقتين المعاكستين.

TO CONNECT SEVERAL PHOTOCELLS, REFER TO FIG. F

لتوصيل عدة خلايا ضوئية، راجع الشكل F

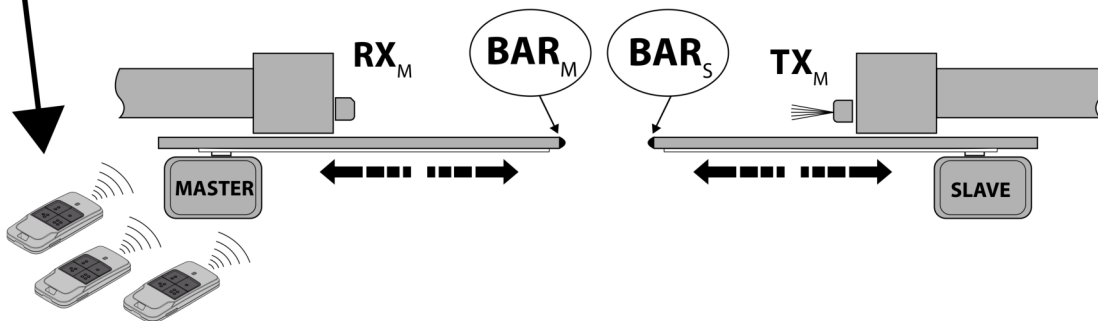



RESTORING FACTORY SETTINGS

WARNING: this operation will restore the control unit's factory settings and all transmitters stored in its memory will be deleted.
WARNING! Incorrect settings can result in damage to property and injury to people and animals.

استعادة ضبط المصنع

تحذير: ستؤدي هذه العملية إلى استعادة ضبط المصنع لوحدة التحكم وسيتم حذف جميع الناقلات المخزنة في ذاكرتها.
تحذير! قد تؤدي الإعدادات غير الصحيحة إلى حدوث تلف في الممتلكات والحاق الإصابة بالأشخاص والحيوانات.

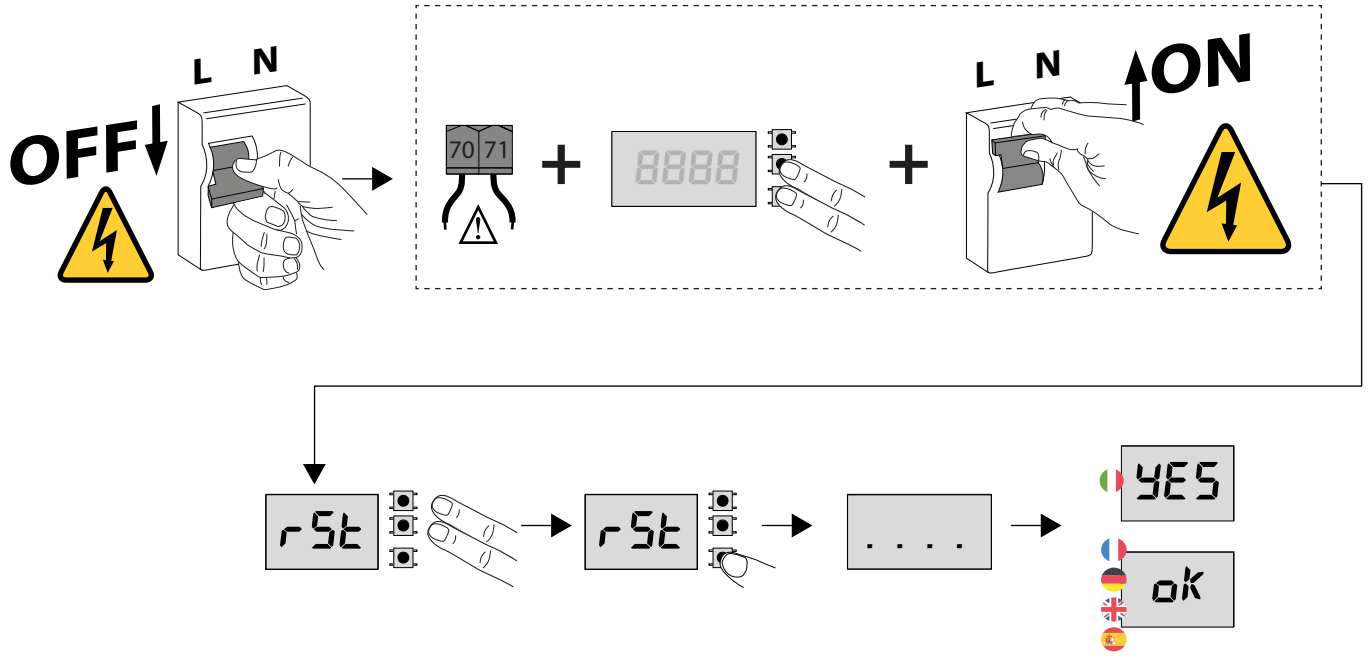

ENGLISH

SIMPLIFIED MENU

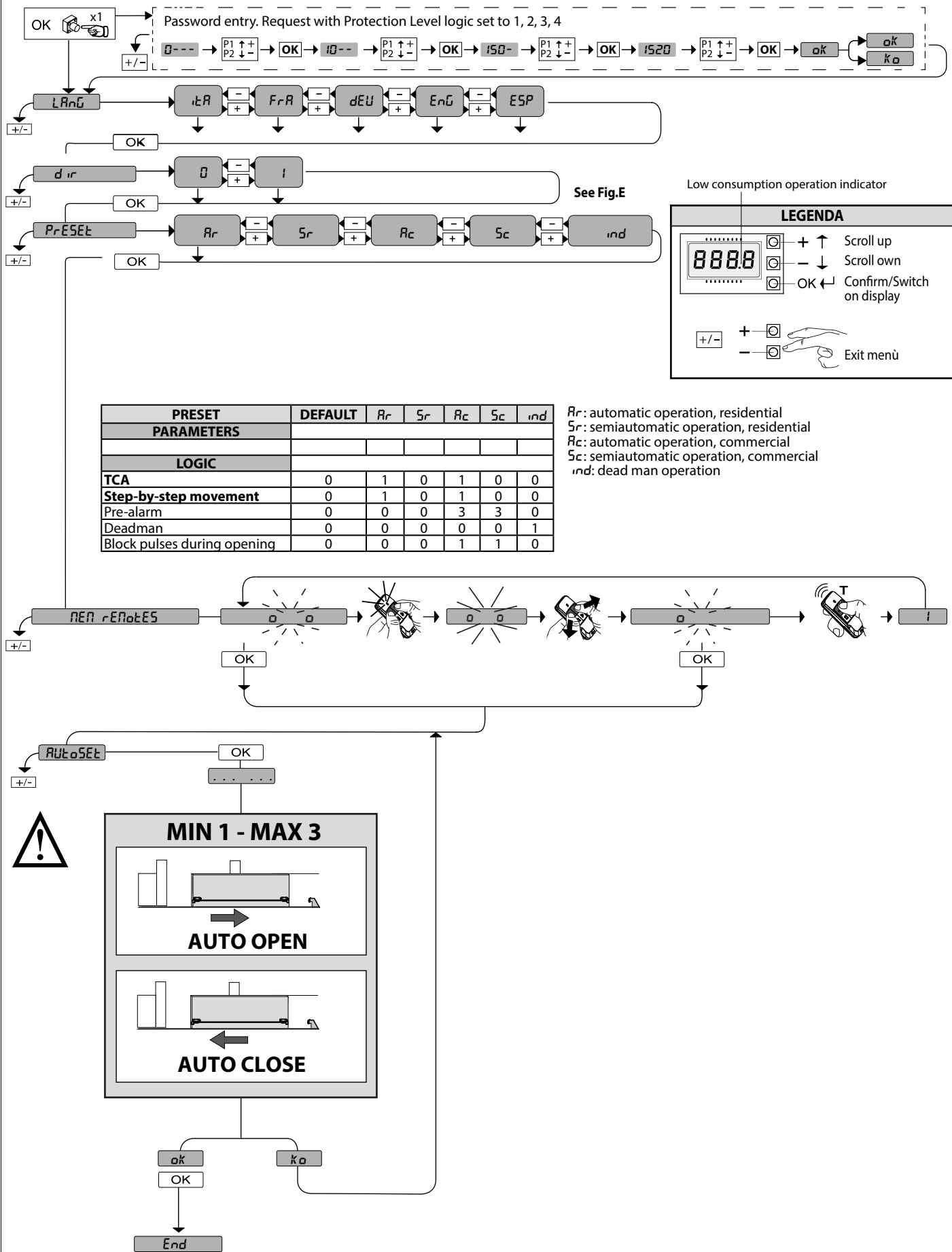

Low consumption operation indicator

LEGENDA

+ ↑	Scroll up
- ↓	Scroll own
OK ←	Confirm/Switch on display

+/-	+ □	- □	OK ←	Exit menù
-----	-----	-----	------	-----------

PRESET PARAMETERS	DEFAULT	Rr	Sr	Rc	Sc	ind
LOGIC						
TCA	0	1	0	1	0	0
Step-by-step movement	0	1	0	1	0	0
Pre-alarm	0	0	0	3	3	0
Deadman	0	0	0	0	0	1
Block pulses during opening	0	0	0	1	1	0

Rr: automatic operation, residential
Sr: semiautomatic operation, residential
Rc: automatic operation, commercial
Sc: semiautomatic operation, commercial
ind: dead man operation

ACCESS MENUS FIG. 1

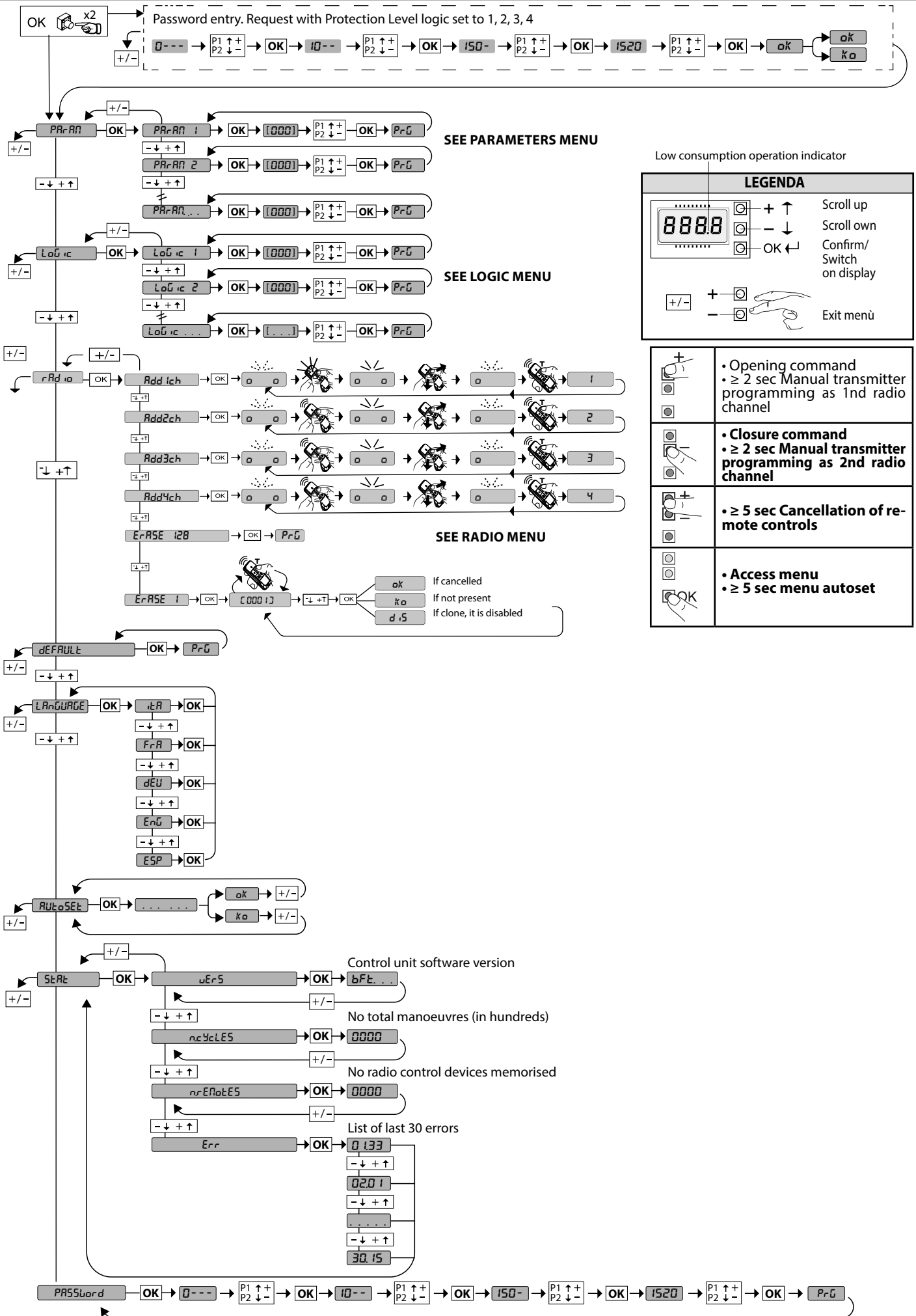



LOW POWER MODE (PSR_{LE}) AND ACCESSORIES

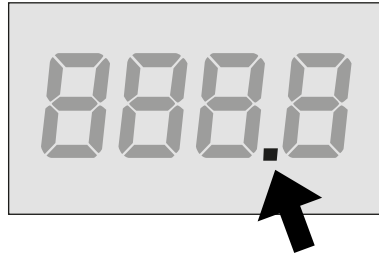

low power mode active

To save energy, the control unit disconnects the power supply to the accessories (terminals 50-51) 10s after the motor is stopped. All accessories are then switched off, the low-power mode is indicated by a dot on the display.

To enable the setting of accessories (e.g. photocell alignment), it is necessary to set $PSR_{LE}=0$, perform the setting and then set $PSR_{LE}=1$

If accessories requiring uninterrupted power supply are used (e.g. radio receivers) set $PSR_{LE}=0$



DIAGNOSTICS

Diagnosics code	Description	Notes
<i>StRE</i>	START E external start input activated	
<i>StRI</i>	START I internal start input activated	
<i>oPEn</i>	OPEN input activated	
<i>cLS</i>	CLOSE input activated	
<i>PEd</i>	PED pedestrian input activated	
<i>tIME</i>	TIMER input activated	
<i>StoP</i>	STOP input activated	
<i>Phot</i>	Activation of PHOT photocell input or, if configured as verified photocell, Activation of the associated FAULT input	
<i>PhoP</i>	Activation of PHOT OP opening photocell input or, if configured as active verified photocell only when opening, Activation of the associated FAULT input	
<i>PhcL</i>	Activation of PHOT CL closing photocell input or, if configured as active verified photocell only when closing, Activation of the associated FAULT input	
<i>bAr</i>	Activation of BAR safety edge input or, if configured as verified safety edge, Activation of the associated FAULT input	
<i>bAr o</i>	Activation of BAR safety edge input with ACTIVE reversal ONLY WHILE OPENING, or, if configured as verified safety edge active only while opening, Activation of the associated FAULT input	
<i>bAr c</i>	Activation of BAR safety edge input with ACTIVE reversal ONLY WHILE CLOSING, or, if configured as verified safety edge active only while closing, Activation of the associated FAULT input	
<i>SEt</i>	The board is standing by to perform a complete opening-closing cycle uninterrupted by intermediate stops in order to acquire the torque required for movement. WARNING! Obstacle detection not active	
<i>Er01</i>	Photocell test failed	Check photocell connection and/or logic settings
<i>Er02</i>	Safety edge test failed	Check safety edge connection and/or logic settings
<i>Er03</i>	Opening photocell test failed	Check photocell connection and/or parameter/ logic setting
<i>Er04</i>	Closing photocell test failed	Check photocell connection and/or parameter/ logic setting
<i>Er06</i>	8k2 safety edge test failed	Check safety edge connection and/or parameter/ logic settings
<i>Er07</i>	Opening safety edge test failed	Check safety edge connection and/or parameter/ logic settings
<i>Er08</i>	Closing safety edge test failed	Check safety edge connection and/or parameter/ logic settings
<i>Er09</i>	Short circuit test between 2 adjacent safety inputs failed.	Check the safety input connection
<i>Er 1H*</i>	Test hardware card error	- Check connections to motor - Hardware problems at the board (contact technical assistance)
<i>Er 3H*</i>	Reverse due to obstacle - Amperostop	Check for obstacles in the path



INSTALLATION MANUAL

D814459 OAR16_08

Diagnostics code	Description	Notes
<i>Er4H*</i>	Thermal	Wait for automated device to cool
<i>Er5H*</i>	Communication error with remote devices	Check connection with serial-connected accessory devices and/or expansion boards
<i>Er72</i>	Consistency error of the control unit's parameters (Logics and Parameters)	Press OK to confirm the detected settings. The board will keep on working with the detected settings. ⚠ Board settings must be checked (Parameters and Logics).
<i>Er73</i>	D-track parameter error	Press OK for the board to keep on working with D-track as a default. ⚠ An autotest is required
<i>ErB3</i>	EEPROM memory error	Check that the memory card has been inserted correctly, try turning the card off and on again. If the problem persists, contact technical assistance.
<i>ErBH* - Er9H*</i>	Internal system supervision control error.	Try switching the board off and back on again. If the problem persists, contact technical assistance.
<i>ErF2</i>	Power supply overload	
<i>ErF3</i>	Error in the logics setting (SAFE inputs, motor type)	Check that the SAFE logic or motor type configuration is correct
<i>ErF4</i>	Auxiliary power output overload	-Check the auxiliary power connections. -Check the total power absorption of the auxiliaries
<i>ErF9</i>	Electric lock output overload	- Check lock connections - Insufficient lock

*H= 0, 1, .., 9, A, B, C, D, E, F

1) IN GENERAL

The control panel is supplied by the Manufacturer with standard factory settings. Any changes must be set via the built-in display controller.

Its main features are:

- Control of 1 24V BT motors
- Electronic torque control with obstacle detection
- Separate inputs for safety devices
- Radio receiver with built-in rolling code.

The board has a removable terminal strip to facilitate maintenance or replacement operations. It comes with a series of prewired jumpers to make the installer's job on site easier.

The jumpers relate to the terminals: 70-71, 70-72, 70-73. If the aforementioned terminals are being used, remove the relevant jumpers.

2) VERIFICATION

The panel controls (checks) the start relays and safety devices (photocells) before performing each opening and closing cycle.

If there is a malfunction, make sure that the connected devices are operating correctly and check the wiring.

3) TUBE PRE-ARRANGEMENT Fig. A**4) TERMINAL BOARD WIRING Fig. B**

WARNINGS - When performing wiring and installation, refer to the standards in force and, whatever the case, apply good practice principles.

Wires carrying different voltages must be kept physically separate from each other, or they must be suitably insulated with at least 1mm of additional insulation. Wires must be secured with additional fastening near the terminals, using devices such as cable clamps.

All connecting cables must be kept at a suitable distance from the dissipater.

WARNING! For connection to the mains power supply, use a multi-core cable with a minimum cross-section 2x1,5 mm² and of the type indicated by regulations in force.

To connect the motor, use a cable with a cross-sectional area of at least 1.5 mm² of the kind provided for by the regulations in force. The cable must be type H05RN-F at least.

5) TECHNICAL DATA

	DEIMOS ULTRA BT B 400	DEIMOS ULTRA BT B 600	ARES ULTRA BT B 1000	ARES ULTRA BT B 1500	ARES VELOCE BT B 500	ARES VELOCE BT B 1000
Power supply	220-230V 50/60 Hz					
Stand-by consumption	0.43 W					
Max. power	80 W	100 W	130 W	160 W		
Radio frequency	433.92 MHz					
Operating temperature	-20 / +60°C					
Thermal protection	Software					
Accessories power supply	24V --- (≤ 0.5 A)					
AUX 1	Energized contact 24V--- N.O. (≤ 1A)					
AUX 2	N.O. contact. (24V ≈ / ≤ 1A)					
Max.n° of radio controls that can be saved	128					
	2048 (only with expansion kit)					

Usable transmitter versions:

All ROLLING CODE transmitters compatible with



	Terminal	Definition	Description	
Power supply	L	PHASE	Single-phase power supply 220-230V 50/60 Hz	
	N	NEUTRAL		
Motor	10	MOT1 +	Connection motor 1. Check connections shown in Fig.E.	
	11	MOT1 -		
Aux	20	AUX 1 - CONTACT POWERED 24V--- (≤ 1A)	AUX 1 configurable output - Default setting FLASHING. 2nd RADIO CHANNEL/ SCA GATE OPEN LIGHT/ COURTESY LIGHT command/ ZONE LIGHT command/ STAIR LIGHT/ GATE OPEN ALARM/ FLASHING LIGHT/ MAINTENANCE/ FLASHING LIGHT AND MAINTENANCE. Refer to "AUX output configuration" table.	
	21			
	26	AUX 2 - FREE CONTACT (N.O.) (24V ≈ / ≤ 1A)		AUX 2 Configurable output - Default output 2nd RADIO CHANNEL. 2nd RADIO CHANNEL/ SCA GATE OPEN LIGHT/ COURTESY LIGHT command/ ZONE LIGHT command/ STAIR LIGHT/ GATE OPEN ALARM/ FLASHING LIGHT. Refer to "AUX output configuration" table.
	27			
Power supply Accessories	50	24V-	Accessories power supply output.	
	51	24V+		
	52	24 Vsafe+		Power supply output for checked safety devices (photocell transmitter and safety edge transmitter). Output only active during the operation cycle.
Commands	60	COM IC	IC 1 and IC 2 inputs common	
	61	IC 1	Configurable control input 1 (N.O.) - Default START E. START E / START I / OPEN / CLOSE / PED / TIMER / TIMER PED Refer to the "Control input configuration" table.	
	62	IC 2	Configurable control input 2 (N.O.) - Default PED. START E / START I / OPEN / CLOSE / PED / TIMER / TIMER PED Refer to the "Control input configuration" table.	
Safety devices	70	COM	STOP, SAFE 1 and SAFE 2 inputs common	
	71	STOP	The command stops the movement. (N.C.) If not used leave the jumper inserted.	
	72	SAFE 1	Configurable safety input 1 (N.C.) - Default PHOT. PHOT / PHOT TEST / PHOT OP / PHOT OP TEST / PHOT CL / PHOT CL TEST / BAR / BAR TEST / BAR 8K2 / BAR OP / BAR OP TEST / BAR 8K2 OP / BAR CL / BAR CL TEST / BAR 8K2 CL Refer to the "Safety input configuration" table.	
	73	SAFE 2	Configurable safety input 2 (N.C.) - Default BAR. PHOT / PHOT TEST / PHOT OP / PHOT OP TEST / PHOT CL / PHOT CL TEST / BAR / BAR TEST / BAR 8K2 / BAR OP / BAR OP TEST / BAR 8K2 OP / BAR CL / BAR CL TEST / BAR 8K2 CL Refer to the "Safety input configuration" table.	
Antenna	Y	ANTENNA	Antenna input.	
	#	SHIELD	Use an antenna tuned to 433MHz. Use RG58 coaxial cable to connect the Antenna-Receiver. Metal bodies close to the antenna can interfere with radio reception. If the transmitter range is limited, move the antenna to a more suitable position.	

INSTALLATION MANUAL

D814459 OAR16_08

AUX output configuration

Aux logic = 0 - MONOSTABLE RADIO CHANNEL output. The contact remains closed for 1s when the radio channel is activated.
Aux logic= 1 - SCA GATE OPEN LIGHT output. The contact remains closed during opening and when the leaf is open, intermittent during closing, open with leaf closed.
Aux logic= 2 - COURTESY LIGHT control output. The contact remains closed for the time set at $t_{L} \text{ rht}$
Aux logic= 3 - ZONE LIGHT command output. The contact remains closed for the duration of the manoeuvre.
Aux logic= 4 - STAIR LIGHT output. Contact stays closed for 1 second at start of manoeuvre.
Aux Logic= 5 - OPEN GATE ALARM Output. Contact stays closed if the leaf stays open for twice the set TCA time.
Aux logic= 6 - FLASHING LIGHT output. The contact remains closed during movement of the leaves.
Aux logic= 7 - Not used
Aux logic= 8 - Not used
Aux logic= 9 - MAINTENANCE output. Contact stays closed once the value set for the Maintenance parameter is reached, to report that maintenance is required.
Aux logic= 10 - FLASHING LIGHT AND MAINTENANCE output. The contact remains closed during movement of the leaves. If the value set for the Maintenance parameter is reached, once the manoeuvre is complete and the leaf is closed, the contact closes for 10 sec. and opens for 5 sec. 4 times to report that maintenance is required.
Aux logic= 11 - Not used
Aux logic= 12 - Not used
Aux Logic = 13 - CLOSED GATE output STATUS. The contact remains closed when the gate is closed.
AUX logic = 14 - BISTABLE RADIO CHANNEL output The contact changes status (open-closed) when the radio channel is activated.
Aux Logic = 15 - TIMED RADIO CHANNEL output. The contact remains closed for a programmable time upon activation of the Radio channel ($t_{\text{out}} \text{ tEP}$) If the button is pressed again during this time, the time count starts again.
Aux logic =16 - OPEN GATE STATUS output. The contact remains closed when the gate is open.

Command input configuration

IC Logic= 0 - Input configured as Start E. Operation according to $5tEP-bY-5tEP$ Logic. External start for traffic light control.
IC Logic= 1 - Input configured as Start I. Operation according to $5tEP-bY-5tEP$ Logic. Internal start for traffic light control.
IC Logic= 2 - Input configured as Open. The command performs an opening. If the input stays closed, the leaves stay open until the contact is opened. When the contact is open, the automation closes after the tca time, if activated.
IC Logic= 3 - Input configured as Closed. The command performs a closure action.
IC Logic= 4 - Input configured as Ped. The command performs a (partial) pedestrian opening action. Operation according to $5tEP-bY-5tEP$ Logic.
IC Logic= 5 - Input configured as Timer. Operation same as open except closing is guaranteed even after a mains power outage.
IC Logic= 6 - Input configured as Timer Ped. The command performs a (partial) pedestrian opening action. If the input stays closed, the leaf stays open until the contact is opened. If the input stays closed and a Start E, Start I or Open command is activated, a complete manoeuvre is performed before returning to the pedestrian opening position. Closing is guaranteed even after a mains power outage.

Safety input configuration

SAFE logic= 0 - Input configured as Phot not verified (*). (fig.F, ref.1). Enables connection of devices not equipped with additional test contacts. In case of obscuration, the photocells are active both in opening and in closing. An obscuration of the photocell during closing, reverses the motion only after the photocell has been disengaged. If not used leave the jumper inserted.
SAFE logic= 1 - Input configured as Phot test, photocell verified). (Fig.F, ref.2). Switches photocell testing on at start of operation. In case of obscuration, the photocells are active both in opening and in closing. An obscuration of the photocell during closing, reverses the motion only after the photocell has been disengaged.
SAFE logic= 2 - Input configured as Phot op, photocell active during opening only, not verified (*) (Fig.F, ref.1). Enables connection of devices not equipped with additional test contacts. If the beam is broken, photocell operation is disabled during closing. During opening, stops motion for as long as the photocell beam stays broken. If not used leave the jumper inserted.
SAFE logic= 3 - Input configured as Phot op test, photocell active during opening only verified (Fig.F, ref.2). Switches photocell testing on at start of operation. If the beam is broken, photocell operation is disabled during closing. During opening, stops motion for as long as the photocell beam stays broken.
SAFE logic= 4 - Input configured as Phot cl, photocell active during closing only not verified (*) (Fig.F, ref.1). Enables connection of devices not equipped with additional test contacts. In case of covering, the photocell operation during opening is excluded. During closing, it immediately reverses. If not used leave the jumper inserted.
SAFE logic= 5 - Input configured as Phot cl test, photocell active during closing only not verified (Fig.F, ref.2). Switches photocell testing on at start of operation. In case of covering, the photocell operation during opening is excluded. During closing, it immediately reverses.
SAFE logic= 6 - Input configured as Bar, safety edge not verified (*) (Fig.F, ref.3). Enables connection of devices not equipped with additional test contacts. The command reverses movement for 2 sec. If not used, leave jumper inserted
SAFE logic= 7 - Input configured as Bar, safety edge verified (Fig.F, ref.4). Activates safety edge test when starting operation. The command reverses movement for 2 sec.
SAFE logic= 8 - Input configured as Bar 8k2 (Fig.F, ref.5). Input for resistive edge 8K2. The command reverses movement for 2 sec.
SAFE logic=9 Input configured as Bar op, safety edge with active inversion only while opening, if activated while closing, the automation stops (STOP) (Fig. F, ref. 3). Enables connection of devices not equipped with additional test contacts. The operation while opening causes the movement to be reversed for 2 seconds, the operation while closing causes the automation to stop. If not used leave the jumper inserted.
SAFE logic=10 Input configured as Bar op test, safety edge verified with active inversion only while opening, if activated while closing, the automation stops (STOP) (Fig. F, ref. 4). Activates safety edge test when starting operation. The operation while opening causes the movement to be reversed for 2 seconds, the operation while closing causes the automation to stop.
SAFE logic=11 Input configured as Bar 8k2 op, 8k2 safety edge with active inversion only while opening, if activated while closing, the automation stops (STOP) (Fig. F, ref. 5). The operation while opening causes the movement to be reversed for 2 seconds, the operation while closing causes the automation to stop.
SAFE logic=12 Input configured as Bar cl, safety edge with active inversion only while closing, if activated while opening, the automation stops (STOP) (Fig. F, ref. 3). Enables connection of devices not equipped with additional test contacts. The operation while closing causes the movement to be reversed for 2 seconds, the operation while opening causes the automation to stop. If not used, leave the jumper inserted

Safety input configuration

SAFE logic=13 Input configured as Bar cl test, safety edge checked with active inversion only while closing, if activated while opening, the automation stops (STOP) (Fig. F, ref. 4). Activates safety edge test when starting operation. The operation while closing causes the movement to be reversed for 2 seconds, the operation while opening causes the automation to stop.

SAFE logic=14 Input configured as Bar 8k2 cl, safety edge with active inversion only while closing, if activated while opening, the automation stops (STOP) (Fig. F, ref. 5). The operation while closing causes the movement to be reversed for 2 seconds, the operation while opening causes the automation to stop.

(*) If "D" type devices are installed (as defined by EN12453), connected in an unverified mode, mandatory maintenance must be carried out at least every six months.

Radio channel control configuration

Logic CH= 0 - Command configured as Start E. Operation according to 5tEP-bY-5tEP Logic. External start for traffic light control.

Logic CH= 1 - Command configured as Start I. Operation according to 5tEP-bY-5tEP Logic. Internal start for traffic light control.

Logic CH= 2 - Control configured as Open.
The command performs an opening.

Logic CH= 3 - Control configured as Close.
The command performs a closure action.

Logic CH= 4 - Control configured as Ped.
The command performs a (partial) pedestrian opening action. Operation according to 5tEP-bY-5tEP Logic.

Logic CH= 5- Control configured as STOP.
The command performs a STOP

Logic CH= 6 - Control configured as AUX1 (**)
The control activates the AUX 1 output

CH logic= 7 - Not used

CH logic= 8 - Not used

Logic CH= 9 - Control configured as AUX2. (**)
The control activates the AUX2 output

CH logic= 10 - Not used

CH logic= 11-Not used

CH logic = 12- Command set up as COURTESY LIGHT
The command enables the light with bi-stable logic. At least one auxiliary output must be set as a courtesy light.

() Active only if the output is configured as Monostable Radio Channel, Courtesy Light, Zone Light, Stair Light, Bistable Radio Channel or Timed Radio Channel.**

6) SAFETY DEVICES

6.1) CHECKED DEVICES Fig. F

6.2) CONNECTING 1 PAIR OF NON-VERIFIED PHOTOCELLS Fig. C

6.3) CONNECTING 1 PAIR OF VERIFIED PHOTOCELLS Fig. D

7) SAVING TRANSMITTERS. Fig. H

8) DELETING TRANSMITTERS Fig. G

9) ACCESS TO MENUS: FIG. 1

9.1) PARAMETERS MENU (PRr PFI) (TABLE "A" PARAMETERS)

9.2) LOGIC MENU (L oG ic) (TABLE "B" LOGIC)

9.3) RADIO MENU (r Ad io) (TABLE "C" RADIO)

9.4) DEFAULT MENU (dEFault)

Resets the control unit to DEFAULT preset values. After the reset, a new AUTOSET must be carried out.

9.5) LANGUAGE MENU (L ANguAGE)

Allows the language of the display controller to be set.

9.6) AUTOSET MENU (AUt oSEt)

- Start an autsetting operation by going to the appropriate menu.
- As soon as the OK button is pressed, the message "... ..", the central control unit commands an opening manoeuvre followed by a closing manoeuvre, during which the minimum torque value necessary for leaf movement is automatically set.

The number of manoeuvres required for the autset can vary from 1 a 3.

During this phase, it is important to avoid blacking out the photocells, as well as using the START and STOP commands and the display.

At the end of this operation, the control unit will have automatically set the optimal torque values. Check them and if necessary modify them as described in programming.

! DANGER! Incorrect installation can result in damage to property and injury to people and animals.

! WARNING!! Check that the impact force value measured at the foreseen points is lower than that indicated in the EN 12453 standard.

! To ensure personal safety and the safety of property, use the passive rubber edge on the main closing edge.

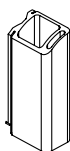

Mod. BFT CSP



Warning!! While the autset function is in operation, the obstacle detection function is not active. The installer must monitor movement of the automated device and keep people and property out of range of the automated device.

For best results, it is advisable to run the autset function with the motor idle (i.e. not overheated by a considerable number of consecutive operations).

9.7) INSTALLATION TEST SEQUENCE

- Run the AUTOSET cycle (*)
- Check the impact forces again. If they observe the limits (**), go to point 10 of the sequence, otherwise
- Adjust speed and sensitivity (force) parameters if necessary: see parameter table.
- Check the impact forces again. If they observe the limits (**), go to point 10 of the sequence, otherwise
- Apply a passive safety edge
- Check the impact forces again. If they observe the limits (**), go to point 10 of the sequence, otherwise
- Apply pressure-sensitive or electro-sensitive protective devices (such as a safety edge) (**)
- Check the impact forces again. If they observe the limits (**), go to point 10 of the sequence, otherwise
- Allow drive movement only in 'Deadman safety' mode
- Make sure all devices designed to detect obstacles within the operating range of the system are working properly

(*) Before running the autset function, make sure you have performed all the assembly and make-safe operations correctly, as set out in the installation warnings in the drive manual.

(**) Based on the risk analysis, you may find it necessary to apply sensitive protective devices

9.8) STATISTICS MENU

Allows the board version to be displayed along with the number of total manoeuvres, the number of stored radio commands and the last 30 errors (the first 2 digits indicate the position, the last 2 the error code). Error 01 is the most recent one. A blinking error indicates the first error after the last maintenance.

9.9) PASSWORD MENU



Allows a password to be set to program the board via the U-link network. With the 'PROTECTION LEVEL' logic set to 1,2,3,4, access to the programming menus is requested. After 10 consecutive failed login attempts, you must wait 3 minutes before making another attempt. During this period, 'BLOC' appears on the display with each access attempt. The default password is 1234.

10) OPTIONAL U-LINK MODULES

Please refer to the instructions of the U-link modules
The use of some modules leads to a reduction in radio range. Adapt the system with a suitable antenna tuned to 433MHz

INSTALLATION MANUAL

TABLE "A" - PARAMETERS - (PARAM)

Parameter	Motors	Min.	Max.	Default	Personal	Definition	Description
t _{cR}		0	120	10		Automatic closing time [s]	Waiting time before automatic closing.
PEd t _{cR}		0	120	0		Automatic closing time from pedestrian manoeuvre [s]	Waiting time before automatic closure after a pedestrian manoeuvre, ONLY if different from 0. If the parameter is set to 0, the waiting time after a pedestrian manoeuvre is the same as the non-pedestrian manoeuvre.
t _{rF} L _{ght} c _{Lr} t		1	180	40		Time-to-clear traffic light zone [s]	Time-to-clear for the zone affected by the traffic controlled by the traffic light.
t _L L _{ght}		30	300	90		Lighting time of the courtesy light [s]	Lighting duration of the courtesy light.
oUtPUt t _{ME}		1	240	10		Activation time of the timed output [s]	Timed radio channel output activation time in seconds
oP. d _{St} S _{lowd}		1 (***)	100	10		Slow-down distance during opening [%]	Slow-down distance for the motor during opening, given as a percentage of total travel. WARNING: Once the parameter has been edited, a complete uninterrupted opening-closing cycle is required. WARNING: when the display reads "SET", obstacle detection is not active. WARNING: with actuators with integrated locks, the permanently active slowdown to a value higher than 5 is mandatory.
cL. d _{St} S _{lowd}		1 (***)	100	10		Slow-down distance during closing [%]	Slow-down distance for motor during closing, given as a percentage of total travel. WARNING: Once the parameter has been edited, a complete uninterrupted opening-closing cycle is required. WARNING: when the display reads "SET", obstacle detection is not active. WARNING: with actuators with integrated locks, the permanently active slowdown to a value higher than 5 is mandatory.
d _{St} d _{EE} L		0	100	25		Slow-down distance [%]	Deceleration distance (switch from running speed to slow-down speed) for motor both during opening and during closing, given as a percentage of total travel. WARNING: Once the parameter has been edited, a complete uninterrupted opening-closing cycle is required. WARNING: when the display reads "SET", obstacle detection is not active.
PEd oPEn _{ing}		10	100	30		Partial opening [%]	Partial opening distance as a percentage of total opening following activation of PED pedestrian command.
oPForcE		1	100	50		Leaf force during opening [%]	Force exerted by leaf during opening. This is the percentage of force delivered, beyond the force stored during the autoset cycle (and subsequently updated), before an obstacle alarm is generated. The parameter is set automatically by the autoset function.  WARNING: Directly affects the impact force. Make sure that current safety regulations are met (*) with the set value. Install anti-crush safety devices where necessary(**).
cLSForcE		1	100	50		Leaf force during closing [%]	Force exerted by leaf during closing. This is the percentage of force delivered, beyond the force stored during the autoset cycle (and subsequently updated), before an obstacle alarm is generated. The parameter is set automatically by the autoset function.  WARNING: Directly affects the impact force. Make sure that current safety regulations are met (*) with the set value. Install anti-crush safety devices where necessary(**).
oP.SL _{owd} ForcE		1	100	50		Leaf force during opening during slow-down [%]	Force exerted by leaf during opening. This is the percentage of force delivered, beyond the force stored during the autoset cycle (and subsequently updated), before an obstacle alarm is generated. The parameter is set automatically by the autoset function.  WARNING: Directly affects the impact force. Make sure that current safety regulations are met (*) with the set value. Install anti-crush safety devices where necessary(**).
cL.SL _{owd} ForcE		1	100	50		Leaf force during closing during slow-down [%]	Force exerted by leaf during closing. This is the percentage of force delivered, beyond the force stored during the autoset cycle (and subsequently updated), before an obstacle alarm is generated. The parameter is set automatically by the autoset function.  WARNING: Directly affects the impact force. Make sure that current safety regulations are met (*) with the set value. Install anti-crush safety devices where necessary(**).
S _{uc} Pr _{ESS} urE ForcE		0	100	100		Leaf pressure force on the closure limit-switch [%]	The force exerted by the leaf during the pressure on the closure limit-switch.
oP SPEED		15	100	100		Opening speed [%]	Percentage of maximum speed that can be reached by motor during opening. WARNING: Once the parameter has been edited, a complete uninterrupted opening-closing cycle is required. WARNING: when the display reads "SET", obstacle detection is not active.
cL SPEED		15	100	100		Closing speed [%]	Percentage of maximum speed that can be reached by motor during closing. WARNING: Once the parameter has been edited, a complete uninterrupted opening-closing cycle is required. WARNING: when the display reads "SET", obstacle detection is not active.

D814459 OAR16_08

INSTALLATION MANUAL

Parameter	Motors	Min.	Max.	Default	Personal	Definition	Description
SLoW SPEED	DEIMOS ULTRA BT B 400/600	15	25	15		Slow-down speed [%]	Opening and closing speed of motor during slow-down stage, given as a percentage of maximum running speed. WARNING: Once the parameter has been edited, a complete uninterrupted opening-closing cycle is required. WARNING: When the display reads "SET", obstacle detection is not active.
	ARES ULTRA BT B 1000/1500	10	25	10			
MaintEnAnCE		0	250	0		Programming of number of operations for maintenance threshold [in hundreds]	Allows a number of operations to be set after which the need for maintenance will be reported on the AUX output configured as Maintenance or Flashing Light and Maintenance

(* In the European Union, apply standard EN 12453 for force limitations.

(**) Impact forces can be reduced by using deformable edges.

(***) Se il valore calcolato risulta inferiore di 30 cm, viene impostato a 30 cm.

TABLE "B" - LOGIC - (LOGIC)

Logic	Definition	Default	Check (tick) the setting made	Options																												
tCRA	Automatic Closure	0	0 1	Logic not active Activates automatic closing																												
RctAL nRcc	Power Down activation	1	0 1	Power Down DEACTIVATED, i.e. the power supply of the accessories is always present. The stand-by consumption with deactivated logic is > 0.5 W Power Down ACTIVE, i.e. the power supply of the accessories is deactivated with the gate stopped.																												
ULink 1	Activates ULink Protocol	0	0 1	Both U-Link connectors support the new U-Link2.0 protocol. Enabling of the U-Link protocol (previous version) on the optional board connector 1. The previous version of the U-Link protocol can be activated on connector 1.																												
FRSt cLS.	Rapid closing	0	0 1	Logic not active Closes 3 seconds after the photocells are cleared before waiting for the end of the set TCA																												
bAtE cOnF iG	Battery config.	0	0 1 2 3	No operative change. Total opening and waiting for the power to come back on. Partial opening based on the "partial opening" parameter, and waiting for the power to come back on. Total closure and wait for the power to come back on.																												
StEP-by-StEP nOUEntE	Step-by-step Movement	0	0 1 2	Inputs configured as Start E, Start I, Ped operate with 4-step logic. Inputs configured as Start E, Start I, Ped operate with 3-step logic. Pulse during closing reverses movement. Inputs configured as Start E, Start I, Ped operate with 2-step logic. With every impulse, the movement is reversed.																												
				<table border="1" style="width: 100%; text-align: center;"> <thead> <tr> <th colspan="4">step-by-step movement</th> </tr> <tr> <th></th> <th>2 STEPS</th> <th>3 STEPS</th> <th>4 STEPS</th> </tr> </thead> <tbody> <tr> <td>CLOSED</td> <td></td> <td></td> <td>OPENS</td> </tr> <tr> <td>DURING CLOSING</td> <td>OPENS</td> <td>OPENS</td> <td>STOP</td> </tr> <tr> <td>OPEN</td> <td></td> <td>CLOSES</td> <td>CLOSES</td> </tr> <tr> <td>DURING OPENING</td> <td>CLOSES</td> <td>STOP + tca</td> <td>STOP + tca</td> </tr> <tr> <td>AFTER STOP</td> <td>OPENS</td> <td>OPENS</td> <td>OPENS</td> </tr> </tbody> </table>	step-by-step movement					2 STEPS	3 STEPS	4 STEPS	CLOSED			OPENS	DURING CLOSING	OPENS	OPENS	STOP	OPEN		CLOSES	CLOSES	DURING OPENING	CLOSES	STOP + tca	STOP + tca	AFTER STOP	OPENS	OPENS	OPENS
step-by-step movement																																
	2 STEPS	3 STEPS	4 STEPS																													
CLOSED			OPENS																													
DURING CLOSING	OPENS	OPENS	STOP																													
OPEN		CLOSES	CLOSES																													
DURING OPENING	CLOSES	STOP + tca	STOP + tca																													
AFTER STOP	OPENS	OPENS	OPENS																													
PrE-ALArn	Pre-alarm	0	0 1-10	The flashing light starts at the same time as the motor starts. The pre-warning function is activated: the flashing light comes on before the motor starts; the value of the parameter indicates the duration of the pre-flashing in seconds.																												
hOId-tO-rUn	Deadman safety device	0	0 1 2 3	Pulse operation. Deadman safety mode. Input 61 is configured as OPEN UP. Input 62 is configured as CLOSE UP. Operation continues as long as the OPEN UP or CLOSE UP keys are held down. WARNING: safety devices are not active. Emergency Deadman Safety mode. Usually pulse operation. If the board fails the safety device tests (photocell or safety edge, Er0x) 3 times in a row, the device is switched to Deadman mode, which will stay active until the OPEN UP or CLOSE UP keys are released. Input 61 is configured as OPEN UP. Input 62 is configured as CLOSE UP. WARNING: with the device set to Emergency Deadman mode, safety devices are not enabled. Dead-man function during closing. Input 61 is configured as OPEN UP. Input 62 is configured as CLOSE UP. The opening manoeuvre occurs automatically, the closing manoeuvre continues until the control button (CLOSE) is pressed. WARNING: safety devices are not active during the closure.																												
aPEr iBL	Opening impulse block	0	0 1	Pulse from inputs configured as Start E, Start I, Ped has effect during opening. Pulse from inputs configured as Start E, Start I, Ped has no effect during opening.																												
tCRA iBL	Block pulses during TCA	0	0 1	Pulse from inputs configured as Start E, Start I, Ped has effect during TCA pause. Pulse from inputs configured as Start E, Start I, Ped has no effect during TCA pause.																												
cLOSE iBL	Block pulses during closing	0	0 1	Pulse from inputs configured as Start E, Start I, Ped has effect during closing. Pulse from inputs configured as Start E, Start I, Ped has no effect during closing.																												

INSTALLATION MANUAL

D814459 OAR16_08

Logic	Definition	Default	Check (tick) the setting made	Options
rAn bLob c. oP	Hammer during opening	0	0	Logic not active
			1	Before opening completely, the gate pushes for approx. 2 seconds as it closes. This allows the electric lock to release more easily. IMPORTANT - Do not use this function without adequate mechanical end stops.
rAn bLob c. cL	Hammer during closing	0	0	Logic not active
			1	Before closing completely, the gate pushes for approx. 2 seconds as it opens. This allows the electric lock to release more easily. IMPORTANT - Do not use this function without adequate mechanical end stops.
bLoc PErS iSt	Block holding	0	0	Logic not active
			1	If the motor stays idle in a fully open or fully closed position for more than one hour, they are switched on in the direction of the stop for approx. 3 seconds. This operation is performed every hour. IMPORTANT - Do not use this function without adequate mechanical end stops.
PrESS Sbc	Closure limit switch pressure	0	0	Movement is stopped only when the closure limit-switch trips: in this case, the tripping of the closure limit-switch must be adjusted accurately (Fig.G Ref.B).
			1	To be used with mechanical closure stop. This function activates pressure of the leaf on the mechanical stop, without this being considered an obstacle by the amperostop sensor. The leaf therefore continues its stroke for a few seconds after interception of the closure limit switch or up to the mechanical stop. In this manner, by slightly advancing the intervention of the closure limit switch, the leaf will come into perfect contact with the end stop.
iCE	Ice Function	0	0	The Amperostop safety trip threshold stays at the same set value.
			1	The controller automatically adjusts the obstacle alarm trip threshold at each start up. Check that the force of impact measured at the points provided for by standard EN 12445 is lower than the value established by standard EN 12453. If in doubt, use auxiliary safety devices. This feature is useful when dealing with installations running at low temperatures. WARNING: once this function has been activated, an autoset opening and closing cycle is required.
iNStALLARt iOn ALtERnARt iUE	Installation alternative		0	See Fig.E
			1	See Fig.E
1 SAFE	Configuration of safety input SAFE 1. 72	0	0	Input configured as Phot, photocell.
			1	Input configured as Phot test, verified photocell.
			2	Input configured as Phot op, photocell active during opening only.
			3	Input configured as Phot op test, photocell active during opening only verified.
			4	Input configured as Phot cl, photocell active during closing.
			5	Input configured as Phot cl test, photocell active during closing only verified.
			6	Input configured as Bar, safety edge.
2 SAFE	Configuration of safety input SAFE 2. 73	6	8	Input configured as Bar 8k2. (Not active on SAFE 11,13).
			9	Input configured as Bar OP, safety edge with reverse active only while opening. The movement stops while closing.
			10	Input configured as Bar OP TEST, safety edge verified with reverse active only while opening. The movement stops while closing.
Only with expansion board. If you do not use the expansion board, leave the default setting (15)	Configuration of safety input SAFE10. 77	15	11	Input configured as Bar OP 8k2, safety edge with reverse active only while opening. The movement stops while closing. (Not active on SAFE 11,13).
			12	Input configured as Bar CL, safety edge with inversion active only while closing. The movement stops while opening.
			13	Input configured as Bar CL TEST, safety edge verified with inversion active only while closing. The movement stops while opening.
			14	Input configured as Bar CL 8k2, safety edge with reverse active only while closing. The movement stops while opening. (Not active on SAFE 11,13).
	Configuration of safety input SAFE12. 79	15	15	Input configured as deactivated. To be used without the expansion board. (Not active on Safe 1,2).
1 IC	Configuration of command input IC 1. 61	0	0	Input configured as Start E.
			1	Input configured as Start I.
			2	Input configured as Open.
			3	Input configured as Close.
2 IC	Configuration of command input IC 2. 62	4	4	Input configured as Ped.
			5	Input configured as Timer.
Only with expansion board	Configuration of command input IC 10. 64	2	6	Input configured as Pedestrian Timer.

INSTALLATION MANUAL

Logic	Definition	Default	Check (tick) the setting made	Options			
1ch	Configuration of the 1st radio channel command	0	0	Radio control configured as START E.			
			1	Radio control configured as Start I.			
2ch	Configuration of the 2nd radio channel command	4	2	Radio control configured as Open.			
			3	Radio control configured as Close			
			4	Radio control configured as Ped			
			5	Radio control configured as STOP			
			6	Radio config. command as AUX1 **			
3ch	Configuration of the 3rd radio channel command	9	7	Not used			
			8	Radio control configured as AUX11 ** (only with an expansion board)			
			9	Radio config. command as AUX2 **			
			10	Not used			
4ch	Configuration of the 4th radio channel command	5	11	Not used			
			12	Control configured as COURTESY LIGHT The command enables the light with bi-stable logic. At least one auxiliary output must be set as a courtesy light.			
1RUH	Configuration of AUX 1 output. 20-21	6	0	Output configured as a Monostable Radio Channel			
2RUH	Configuration of AUX 2 output. 26-27	0	1	Output configured as SCA, Gate Open Light.			
			2	Output configured as Courtesy Light command.			
Only with expansion board	10RUH	3	3	Output configured as Zone Light command.			
			4	Output configured as Stair Light.			
			5	Output configured as Alarm.			
			6	Output configured as Flashing light.			
			7	Not used			
			8	Not used			
			9	Output configured as Maintenance			
			10	Output configured as Flashing Light and Maintenance.			
			11	Not used			
			12	Not used			
			13	Output configured as closed Gate Status			
			14	Output configured as a Bistable Radio Channel			
			15	Output configured as a timed Radio Channel			
			16	Output configured as open Gate Status			
			Only with expansion board	10CH	0	0	Output configured for 12V snap-action electric lock---
						1	Output configured for 12V magnetic electric lock---. Max. 0.5 A. Power Down is not active with this setting
2	Output configured for 24V snap-action electric lock---						
3	Output configured for 24V magnetic electric lock---. Max. 0.25 A. Power Down is not active with this setting						
4	Traction lock: active during the entire manoeuvre. Max.: 1 A for 1S, 0.2 A for the rest of the manoeuvre.						
Prot. LEU	Protection level setting	0	0	A - The password is not required to access the programming menus B - Enables the saving of remote controls via radio. Operations in this mode are carried out near the control panel and do not require access: - Press the hidden button and the normal button in sequence (T1-T2-T3-T4) of a remote control already saved in standard mode through the radio menu. - Press the hidden key and normal key (T1-T2-T3-T4) of a radio control to be saved within 10 sec. The receiver exits programming mode after 10 sec.: you can use this time to enter other new radio controls by repeating the previous step. C - Enables automatic insertion of the replays via radio. Enables programmed Replays to be added to the GSM receiver memory. D - The board's parameters can be edited via the U-link network			
			1	A - You are prompted to enter the password to access the programming menus. The default password is 1234. No change in behaviour of function 0 for functions B - C - D			
			3	A - You are prompted to enter the password to access the programming menus. The default password is 1234. B - Saving remote controls via radio is disabled. C - Automatic insertion of the replays via radio is disabled. Function D remains unchanged with respect to function 0			
			4	A - You are prompted to enter the password to access the programming menus. The default password is 1234. B - Saving remote controls via radio is disabled. C - Automatic insertion of the replays via radio is disabled. D - The option of editing the board's parameters via the U-link network is disabled Radio controls are memorized only using the relevant Radio menu.			
SERIAL MODE	Serial mode (Identifies how the board is configured in a BFT network connection)	0	0	SLAVE standard: the board receives and communicates commands/diagnostics/etc.			
			1	MASTER standard: board sends activation commands (START, OPEN, CLOSE, PED, STOP) to other boards.			
			2	SLAVE opposing leafs in local network: the board is the slave in an opposing leaf network without an intelligent module. (fig.E)			
			3	MASTER opposing leafs in local network: the board is the master in an opposing leaf network without an intelligent module. (fig.E)			
Addr-ESS	Address	0	[___]	Identifies board address from 0 to 119 in a local BFT network connection. (see U-LINK OPTIONAL MODULES section)			

INSTALLATION MANUAL

D814459 OAR16_08

Logic	Definition	Default	Check (tick) the setting made	Options
TrAFFic LiGht PrEFLASHing	Traffic light pre-flashing	0	0	Pre-flashing excluded.
			1	Red lights flash, for 3 seconds, at start of manoeuvre.
TrAFFic LiGht rEd LAMP ALwAYS on	Red steady on	0	0	Red lights off when gate closed.
			1	Red lights on when gate closed.

(**) Active only if the output is configured as Monostable Radio Channel, Courtesy Light, Zone Light, Stair Light, Bistable Radio Channel or Timed Radio Channel.

TABLE "C" - RADIO MENU (rAd io)

Logic	Description
Rdd1	Add 1ch key pairs the desired key with the 1st radio channel command
Rdd2	Add 2ch key pairs the desired key with the 2nd radio channel command.
Rdd3	Add 3ch key pairs the desired key with the 3rd radio channel command.
Rdd4	Add 4ch key pairs the desired key with the 4th radio channel command.
cRnc ALL	Delete List  WARNING! Deletes all saved transmitters from the receiver's memory.
cRnc	Eliminates individual radio control Removes a radio control (if replay is disabled). To select the radio control to be deleted, enter the position or press a button on the radio control to be deleted (the position is displayed)